

## Stepping Motor and Driver Package $\alpha$ STEP High-Efficiency **AR Series** DC Power-Supply Input

**FLEX** Built-in Controller Type  
Pulse Input Type

The extensive **AR Series** DC Power-Supply Input lineup that utilizes high-efficiency technology. Two types are available: the built-in controller type equipped with interfaces that connect to a wide variety of host systems and the pulse input type that enables the motor to be controlled from a pulse generator provided by the customer.



# Built-in Controller Drivers Support FLEX, a Feature That Enables You to Select the Control Method in Accordance with Your Operation System.

## What is FLEX?

FLEX is a general name for products that support FA network control via I/O control, Modbus (RTU) control, and network converters.

It makes connections and controls easy and reduces the total lead time for building systems.



## Our Unique Closed Loop Control Providing High Reliability

### ● Continues Operation Even During Abrupt Load Changes and Accelerations

During normal operation, the motor operates synchronously with command pulses in open loop mode. When an overload condition is detected, the motor instantly switches to closed loop mode to correct the rotor position.

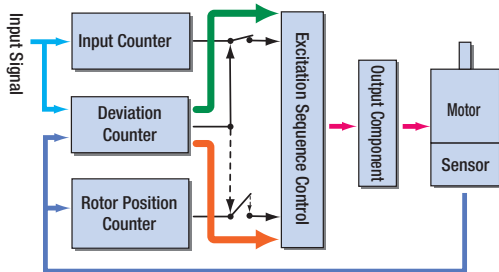

**Normal (Positioning deviation is less than  $\pm 1.8^\circ$ )**

Motor runs in open loop mode like a stepping motor.

**Overload Condition (Positioning deviation is  $\pm 1.8^\circ$  or more)**

The closed loop mode is engaged to maintain the positioning operation.

### ● Rotor Position Detection Sensor (Resolver)

- The sensor is compact and slim, making the overall length of the motor shorter.
- When compared with typical optical encoders, this sensor is superior in heat resistance, vibration resistance, etc.
- As encoder cables are not needed, only a single cable is needed for the connection between the motor and driver.

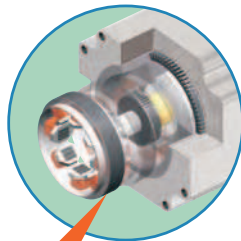

Rotor Position Detection Sensor

### ● Alarm Signal Output in Case of Abnormality

If an overload is applied continuously, an alarm signal is output. When the positioning is complete, an END signal is output. This ensures the same level of reliability achieved by a servo motor.

### ● Also Supports Absolute Systems

You can build an absolute system that detects absolute positions by connecting the accessory battery (sold separately). (available only on the built-in controller type)



● Battery Set (Sold separately)

## Stepping Motor Advantages

### ● Excellent Synchronicity and High Response Operation

#### ◇ Frequent Starting and Stopping

Since they operate synchronously with pulse commands and generate high torque with a compact body, stepping motors offer excellent acceleration performance and response.

They are ideal for applications requiring frequent starting and stopping.

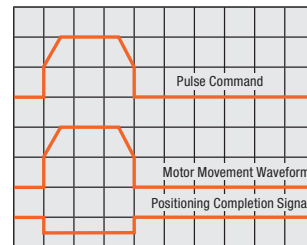

Measurement Condition: Feed 1/5 rotation  
Inertial Load:  $250 \times 10^{-7} \text{ kg} \cdot \text{m}^2 (\text{J})$

### ● No Tuning

Positioning is still possible without gain tuning even when the load fluctuates due to use of a belt mechanism, cam or chain drive, etc.

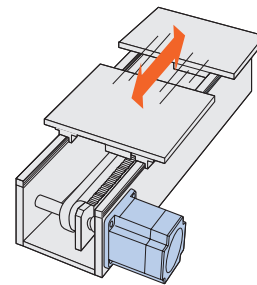

### ● Holding the Stop Position

During positioning, the motor stops with its own holding torque without hunting. Accordingly, stepping motors are ideal for applications where the low rigidity of the mechanism requires absence of vibration upon stop.

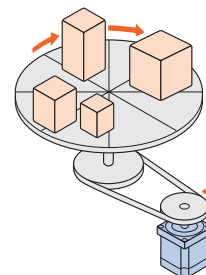

# Connects to a Wide Variety of Host Systems

- Built-in Controller Type
- Pulse Input Type

## Select the Control Method in Accordance with Your Operation System

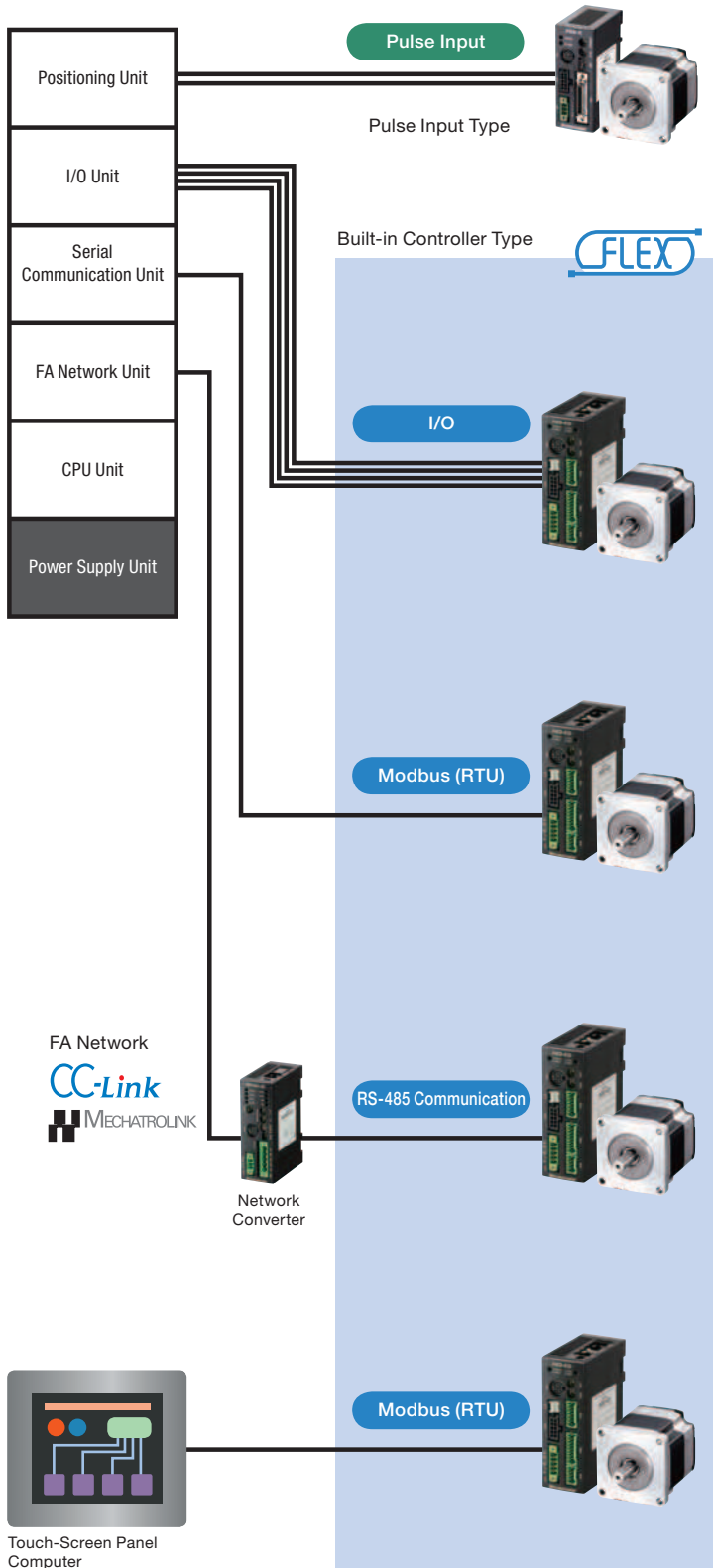

## Representative Systems

**Pulse Input**

The motor can be controlled using a pulse generator provided by the customer. Operating data registered in the pulse generator is selected from the PLC to operate the motor.

**I/O**

The function of a built-in pulse generator lets you build an operation system by connecting directly to a PLC. Since no separate pulse generator is required, the drivers of this type save space and simplify systems.

**Modbus (RTU)**

Through RS-485 communication, you can set operating data and parameters and input operation commands. Up to 31 drivers can be connected to a single serial unit. The unit also has a feature for starting multiple axes simultaneously. The unit supports the Modbus (RTU) protocol, which makes it easy to connect a PLC or similar device to the driver.

**FA Network**

By using a Network Converter (sold separately), you can use CC-Link communication and MECHATROLINK communication. Over these links, operating data and parameters can be set, and operation commands can be sent to the driver.

The following products are available for setting data on built-in controller drivers.

<p><b>Control Module</b> <b>OPX-2A</b> (sold separately) (→ Page 53)</p>	or	<p><b>Data Setting Software</b> <b>MEXE02</b> (→ Page 54)</p> <p><b>Computer</b></p>
--	----	--

You can use these to set drivers' internal parameters and set and change data. You can also use these to set speeds, monitor the I/O, and perform teaching.

Features

Lineup

System Configuration

Product Line

Specifications and Characteristics

Dimension

Connection and Operation

Combination List

Extended Functions

How to Read Specifications and Characteristics

Accessory

Controller

## Highly Functional, Compact Driver

### ● Compact DC Power-Supply Input Driver

The compact DC power input driver makes it possible to reduce the space needed for installing control boxes and devices. The driver can be mounted directly to a DIN rail, so no screws are necessary.

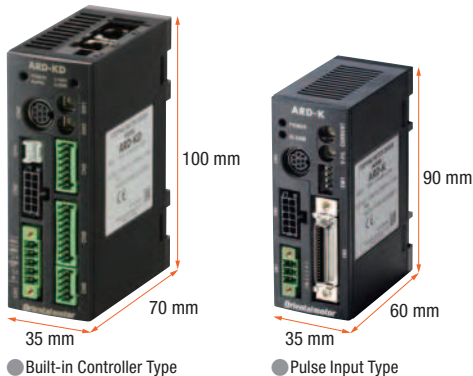

### ● Push-Motion Operation

A force is continuously applied to the load. When contact is made with the load, the motor switches to push-motion operation and applies constant torque to the load.

#### [Note]

- Push-motion operation requires a data module **OPX-2A** (sold separately) or data setting software **MEXE02**.
- Do not perform push-motion operation using geared motors. Doing so may damage the motor or gearhead.

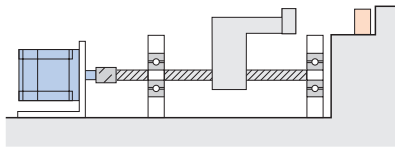

### ● 48 VDC Compatible

The motor runs on a 24 VDC or 48 VDC power supply. Choose the power supply that you have available. The torque is higher when 48 VDC is used rather than 24 VDC. (□28 only accepts 24 VDC input.)

#### AR66SAK-◇

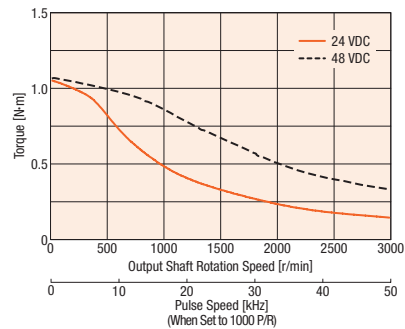

### ● Position Control in the Same Direction

The round feature enables you to control positioning even in an application where positioning is repeated in the same direction (available only on the built-in controller type).

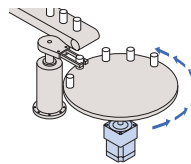

\*Building an absolute system requires an accessory battery (sold separately).

## Continuous Operation is Achieved Due to the Reduction of Motor Heat Generation by Utilizing High-Efficiency Technology.

### ● Lower Heat Generation

Significant reduction in heat generation has been achieved through high-efficiency technology.

#### ● Temperature Distribution by Thermography

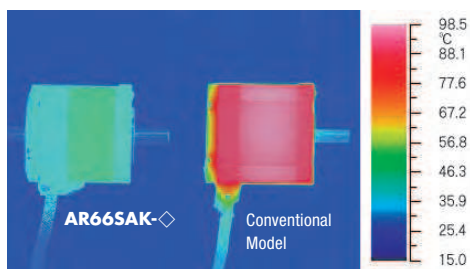

Comparison under the Same Conditions.

#### ● Motor Case Temperature under Same Operating Conditions

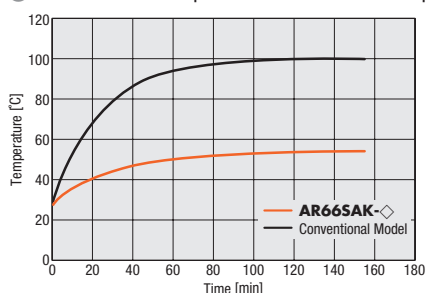

### ● Energy Savings

The power consumption is 30% less than a conventional model (also by Oriental Motor).

#### ● Power Consumption

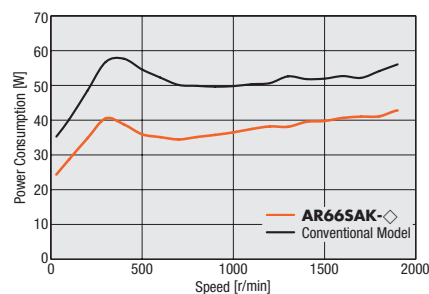

CO<sub>2</sub> emission: **30% less\*** than a conventional model (also by Oriental Motor)

\*Assuming operation at a duty of 40%

### ● Continuous Operation (Operation at high frequency)

The AR Series can be operated at high frequency. You can drive the motor continuously.

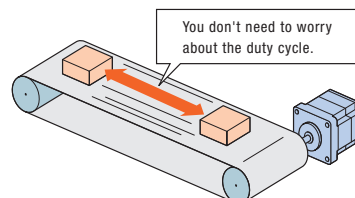





#### [Note]

When the motor is operated continuously, a heat sink of a capacity at least equivalent to an aluminum plate with a size of 100×100 mm, 6 mm thick is required.

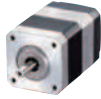
# Motor Lineup

## Types and Features of Standard and Geared Motors

Type	Feature	Gear Ratio	Permissible Torque and Maximum Torque[N·m]	Backlash [min]	Basic Resolution [°/Pulse]	Output Shaft Rotation Speed[r/min]
Standard Type 	● AR Series standard model	—	Max. Holding Torque 2	—	0.36	4000
<b>TH</b> Geared Type (Spur gear mechanism) 	● High speed (Low gear ratio)	1:3.6, 1:7.2, 1:10, 1:20, 1:30 (A wide variety of gear ratios for selecting the desired step angle (Resolution))	12	45	0.012	500
<b>PS</b> Geared Type (Planetary gear mechanism) 	● High speed (Low gear ratio) ● High permissible torque ● High maximum torque ● Center shaft	1:5, 1:7.2, 1:10, 1:25, 1:36, 1:50 (A wide variety of gear ratios for selecting the desired step angle (Resolution))	Permissible Torque 37 Maximum Torque 60	35	0.0072	600
<b>PN</b> Geared Type (Planetary gear mechanism) 	● High speed (Low gear ratio) ● High positioning accuracy ● High permissible torque ● High maximum torque ● Center shaft	1:5, 1:7.2, 1:10, 1:25, 1:36, 1:50 (A wide variety of gear ratios for selecting the desired step angle (Resolution))	Permissible Torque 37 Maximum Torque 60	3	0.0072	600
Harmonic Geared Type (Harmonic drive) 	● High resolution (High gear ratio) ● High positioning accuracy ● High permissible torque ● High maximum torque ● Center shaft	1:50, 1:100	Permissible Torque 37 Maximum Torque 55	0	0.0036	70

### Note

● The values shown above must be used as reference. These values vary depending on the motor frame size and gear ratio.

## Frame Sizes

Four motor frame sizes are available for the built-in controller type and for the pulse input type.

(□42 : indicates a motor frame size of 42 mm)

Motor Type		□28 (□30*1)	□42	□60	□85 (□90*2)
Standard Type	Without Electromagnetic Brake	●	●	●	●
	Electromagnetic Brake Type		●	●	●
<b>TH, PS, PN,</b> Harmonic Geared Type	Without Electromagnetic Brake	●	●	●	●
	Electromagnetic Brake Type		●	●	●

\*1 Harmonic geared type

\*2 Geared type

## Conformance to Various Directives

### ◇ CE Marking

This product has CE Marking affixed under the EMC Directive and Low Voltage Directive.

Product	CE Marking
Motor	Low Voltage Directive
Driver	EMC Directive

● The EMC value changes according to the wiring and layout. Therefore, the final level must be checked with the product incorporated in the user's equipment.

Features

Lineup

System Configuration

Product Line

Specifications and Characteristics

Dimension

Connection and Operation

Combination List

Extended Functions

How to Read Specifications and Characteristics

Accessory

Controller

# System Configuration

## Built-in Controller Type - Standard Type with Electromagnetic Brake

An example of system configuration with I/O control or RS-485 communication is shown below.

\*1 Not supplied.

\*2 Required for I/O control drive.

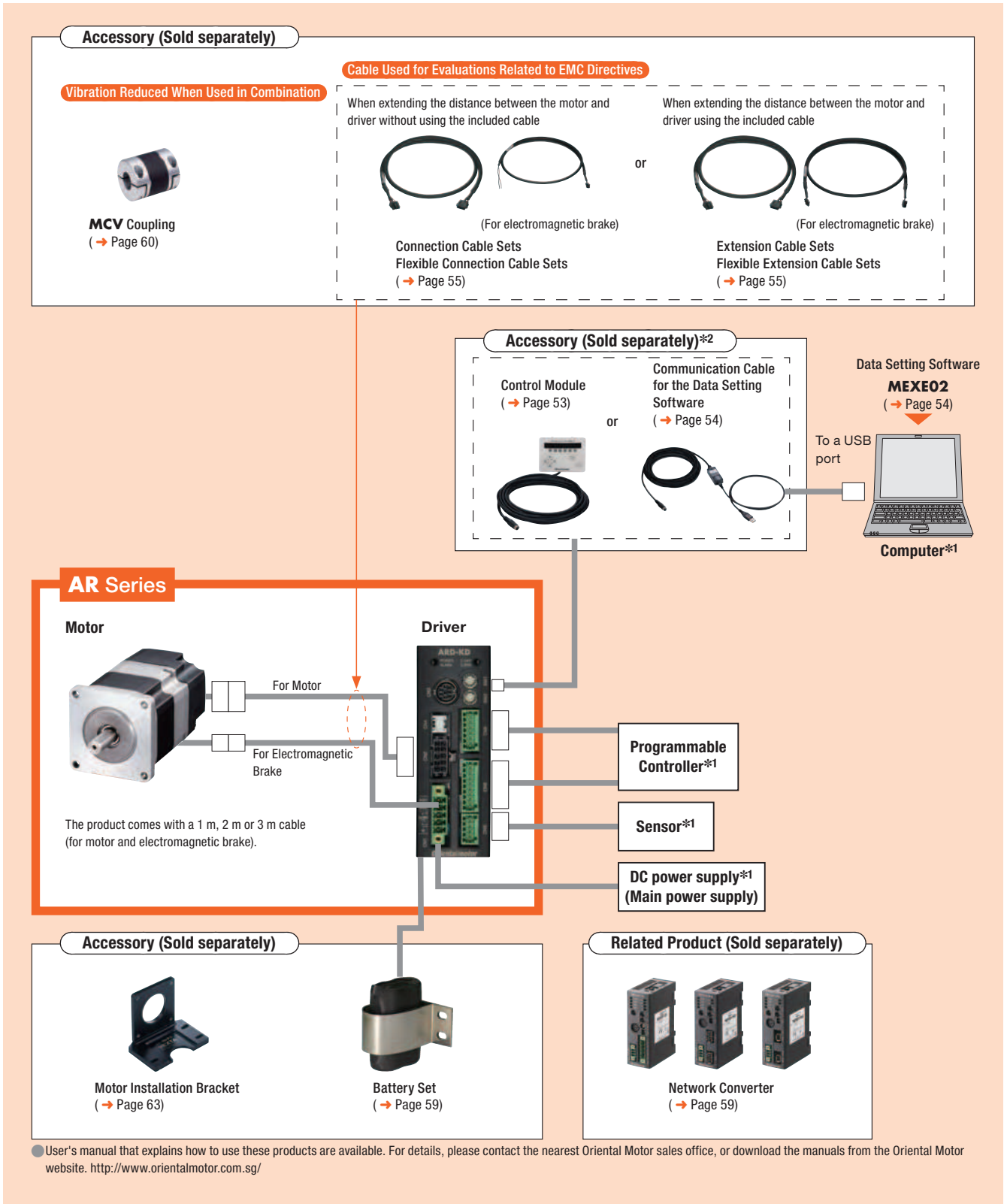

### System Configuration Example

<b>AR Series</b>	+	<b>Sold Separately</b>	
		<b>Motor Installation Bracket</b> <b>PAL2P-5</b>	<b>Flexible Coupling</b> <b>MCV251010</b>

● The system configuration shown above is an example. Other combinations are available.

Features

Lineup

System Configuration

Product Line

Specifications and Characteristics

Dimension

Connection and Operation

Combination List

Extended Functions

How to Read Specifications and Characteristics

Accessory

Controller

## Pulse Input Type - Standard Type with Electromagnetic Brake

An example of a single-axis system configuration with the **PG1200** controller is shown below.

\*Not supplied.

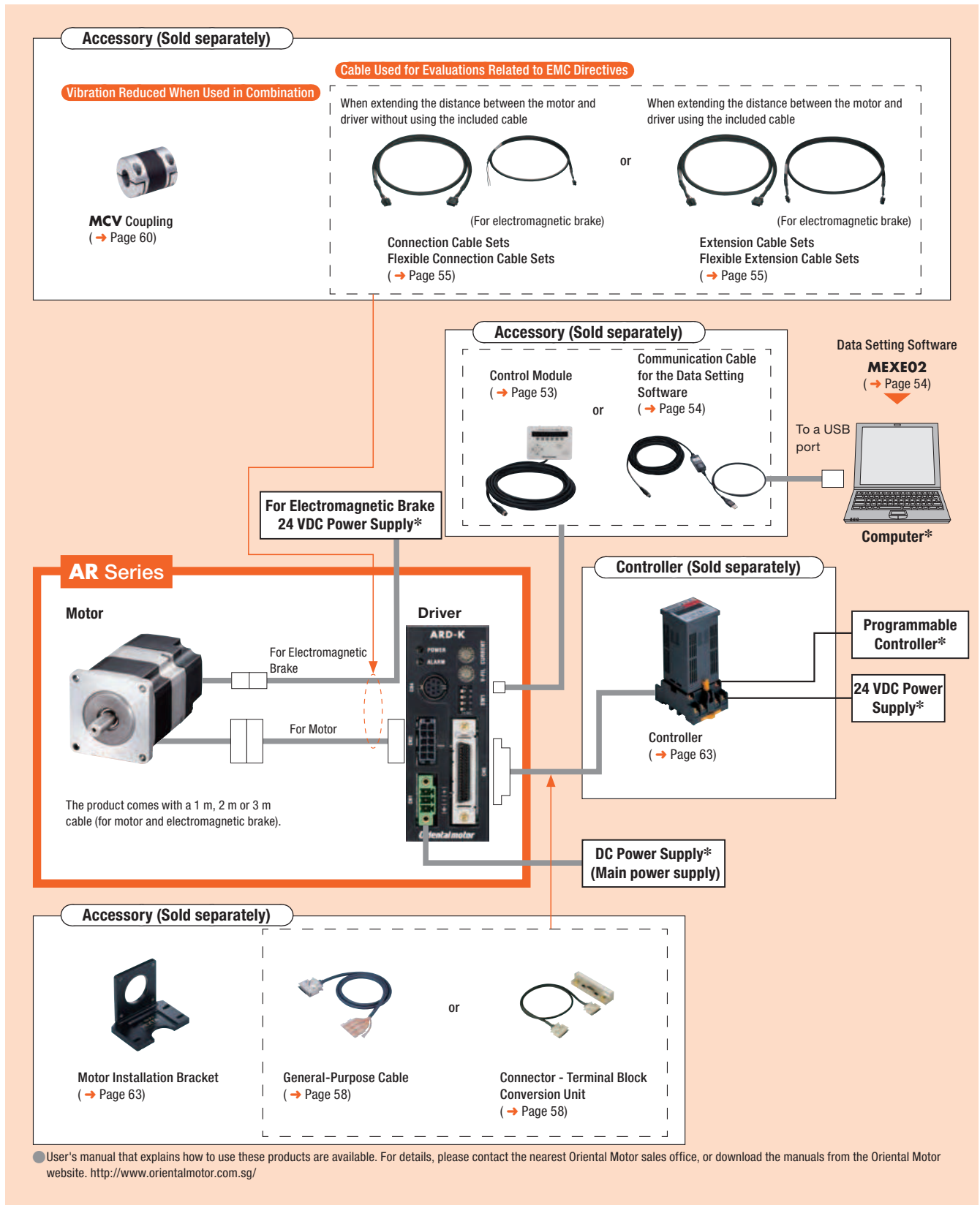

### System Configuration Example

AR Series	Sold Separately			
	Controller	Motor Installation Bracket	Flexible Coupling	Connector - Terminal Block Conversion Unit (1 m)
<b>AR66SMK-3</b>	<b>PG1200</b>	<b>PAL2P-5</b>	<b>MCV251010</b>	<b>CC36T1</b>

● The system configuration shown above is an example. Other combinations are available.

## Product Number Code

# AR 6 6 S A K D - PS 10 - 1

① ② ③ ④ ⑤ ⑥ ⑦ ⑧ ⑨ ⑩

①	Series Name	<b>AR: AR Series</b>	
②	Motor Frame Size	<b>2:</b> 28 mm (30 mm) <b>6:</b> 60 mm	<b>4:</b> 42 mm <b>9:</b> 85 mm (90 mm)
③	Motor Case Length		
④	Motor Classification		
⑤	Configuration	<b>A:</b> Standard (Single shaft) <b>B:</b> Standard (Double shaft) <b>M:</b> Electromagnetic Brake Type	
⑥	Power Supply Input	<b>K:</b> DC Power Supply	

⑦	Driver Type	<b>D:</b> Built-in Controller Type Blank: Pulse Input Type
⑧	Gear Type	Blank: Standard Type <b>T: TH</b> Geared Type <b>PS: PS</b> Geared Type <b>N: PN</b> Geared Type <b>H:</b> Harmonic Geared Type
⑨	Gear Ratio	
⑩	Cable Length (Included)	<b>1:</b> 1 m <b>2:</b> 2 m <b>3:</b> 3 m

## Product Line

### ● Built-in Controller Type

#### ◇ Standard Type

Product Name (Single shaft)	Product Name (Double shaft)
<b>AR24SAKD</b> -◇	<b>AR24SBKD</b> -◇
<b>AR26SAKD</b> -◇	<b>AR26SBKD</b> -◇
<b>AR46SAKD</b> -◇	<b>AR46SBKD</b> -◇
<b>AR66SAKD</b> -◇	<b>AR66SBKD</b> -◇
<b>AR69SAKD</b> -◇	<b>AR69SBKD</b> -◇
<b>AR98SAKD</b> -◇	<b>AR98SBKD</b> -◇

#### ◇ Standard Type with Electromagnetic Brake

Product Name
<b>AR46SMKD</b> -◇
<b>AR66SMKD</b> -◇
<b>AR69SMKD</b> -◇
<b>AR98SMKD</b> -◇

#### ◇ TH Geared Type

Product Name
<b>AR24SAKD-T7.2</b> -◇
<b>AR24SAKD-T10</b> -◇
<b>AR24SAKD-T20</b> -◇
<b>AR24SAKD-T30</b> -◇

#### ◇ TH Geared Type with Electromagnetic Brake

Product Name
-
<b>AR46SMKD-T3.6</b> -◇
<b>AR46SMKD-T7.2</b> -◇
<b>AR46SMKD-T10</b> -◇
<b>AR46SMKD-T20</b> -◇
<b>AR46SMKD-T30</b> -◇
<b>AR66SMKD-T3.6</b> -◇
<b>AR66SMKD-T7.2</b> -◇
<b>AR66SMKD-T10</b> -◇
<b>AR66SMKD-T20</b> -◇
<b>AR66SMKD-T30</b> -◇
<b>AR98SMKD-T3.6</b> -◇
<b>AR98SMKD-T7.2</b> -◇
<b>AR98SMKD-T10</b> -◇
<b>AR98SMKD-T20</b> -◇
<b>AR98SMKD-T30</b> -◇

#### ◇ PS Geared Type

Product Name
<b>AR24SAKD-PS5</b> -◇
<b>AR24SAKD-PS7</b> -◇
<b>AR24SAKD-PS10</b> -◇
<b>AR46SAKD-PS5</b> -◇
<b>AR46SAKD-PS7</b> -◇
<b>AR46SAKD-PS10</b> -◇
<b>AR46SAKD-PS25</b> -◇
<b>AR46SAKD-PS36</b> -◇
<b>AR46SAKD-PS50</b> -◇
<b>AR66SAKD-PS5</b> -◇
<b>AR66SAKD-PS7</b> -◇
<b>AR66SAKD-PS10</b> -◇
<b>AR66SAKD-PS25</b> -◇
<b>AR66SAKD-PS36</b> -◇
<b>AR66SAKD-PS50</b> -◇
<b>AR98SAKD-PS5</b> -◇
<b>AR98SAKD-PS7</b> -◇
<b>AR98SAKD-PS10</b> -◇
<b>AR98SAKD-PS25</b> -◇
<b>AR98SAKD-PS36</b> -◇
<b>AR98SAKD-PS50</b> -◇

#### ◇ PS Geared Type with Electromagnetic Brake

Product Name
-
<b>AR46SMKD-PS5</b> -◇
<b>AR46SMKD-PS7</b> -◇
<b>AR46SMKD-PS10</b> -◇
<b>AR46SMKD-PS25</b> -◇
<b>AR46SMKD-PS36</b> -◇
<b>AR46SMKD-PS50</b> -◇
<b>AR66SMKD-PS5</b> -◇
<b>AR66SMKD-PS7</b> -◇
<b>AR66SMKD-PS10</b> -◇
<b>AR66SMKD-PS25</b> -◇
<b>AR66SMKD-PS36</b> -◇
<b>AR66SMKD-PS50</b> -◇
<b>AR98SMKD-PS5</b> -◇
<b>AR98SMKD-PS7</b> -◇
<b>AR98SMKD-PS10</b> -◇
<b>AR98SMKD-PS25</b> -◇
<b>AR98SMKD-PS36</b> -◇
<b>AR98SMKD-PS50</b> -◇

#### ◇ PN Geared Type

Product Name
<b>AR24SAKD-N5</b> -◇
<b>AR24SAKD-N7.2</b> -◇
<b>AR24SAKD-N10</b> -◇
<b>AR46SAKD-N5</b> -◇
<b>AR46SAKD-N7.2</b> -◇
<b>AR46SAKD-N10</b> -◇
<b>AR66SAKD-N5</b> -◇
<b>AR66SAKD-N7.2</b> -◇
<b>AR66SAKD-N10</b> -◇
<b>AR66SAKD-N25</b> -◇
<b>AR66SAKD-N36</b> -◇
<b>AR66SAKD-N50</b> -◇
<b>AR98SAKD-N5</b> -◇
<b>AR98SAKD-N7.2</b> -◇
<b>AR98SAKD-N10</b> -◇
<b>AR98SAKD-N25</b> -◇
<b>AR98SAKD-N36</b> -◇
<b>AR98SAKD-N50</b> -◇

#### ◇ PN Geared Type with Electromagnetic Brake

Product Name
-
<b>AR46SMKD-N5</b> -◇
<b>AR46SMKD-N7.2</b> -◇
<b>AR46SMKD-N10</b> -◇
<b>AR66SMKD-N5</b> -◇
<b>AR66SMKD-N7.2</b> -◇
<b>AR66SMKD-N10</b> -◇
<b>AR66SMKD-N25</b> -◇
<b>AR66SMKD-N36</b> -◇
<b>AR66SMKD-N50</b> -◇
<b>AR98SMKD-N5</b> -◇
<b>AR98SMKD-N7.2</b> -◇
<b>AR98SMKD-N10</b> -◇
<b>AR98SMKD-N25</b> -◇
<b>AR98SMKD-N36</b> -◇
<b>AR98SMKD-N50</b> -◇

◇ Harmonic Geared Type

Product Name
<b>AR24SAKD-H50</b> -◇
<b>AR24SAKD-H100</b> -◇
<b>AR46SAKD-H50</b> -◇
<b>AR46SAKD-H100</b> -◇
<b>AR66SAKD-H50</b> -◇
<b>AR66SAKD-H100</b> -◇
<b>AR98SAKD-H50</b> -◇
<b>AR98SAKD-H100</b> -◇

◇ Harmonic Geared Type with Electromagnetic Brake

Product Name
-
<b>AR46SMKD-H50</b> -◇
<b>AR46SMKD-H100</b> -◇
<b>AR66SMKD-H50</b> -◇
<b>AR66SMKD-H100</b> -◇
<b>AR98SMKD-H50</b> -◇
<b>AR98SMKD-H100</b> -◇

● A number indicating the desired length of **1** (1 m), **2** (2 m) or **3** (3 m) for the cable included with the product is entered where the box ◇ is located within the product name. Select a desired cable length from 1 m, 2 m and 3 m.

● Pulse Input Type

◇ Standard Type

Product Name (Single shaft)	Product Name (Double shaft)
<b>AR24SAK</b> -◇	<b>AR24SBK</b> -◇
<b>AR26SAK</b> -◇	<b>AR26SBK</b> -◇
<b>AR46SAK</b> -◇	<b>AR46SBK</b> -◇
<b>AR66SAK</b> -◇	<b>AR66SBK</b> -◇
<b>AR69SAK</b> -◇	<b>AR69SBK</b> -◇
<b>AR98SAK</b> -◇	<b>AR98SBK</b> -◇

◇ Standard Type with Electromagnetic Brake

Product Name
<b>AR46SMK</b> -◇
<b>AR66SMK</b> -◇
<b>AR69SMK</b> -◇
<b>AR98SMK</b> -◇

◇ TH Geared Type

Product Name
<b>AR24SAK-T7.2</b> -◇
<b>AR24SAK-T10</b> -◇
<b>AR24SAK-T20</b> -◇
<b>AR24SAK-T30</b> -◇
<b>AR46SAK-T3.6</b> -◇
<b>AR46SAK-T7.2</b> -◇
<b>AR46SAK-T10</b> -◇
<b>AR46SAK-T20</b> -◇
<b>AR46SAK-T30</b> -◇
<b>AR66SAK-T3.6</b> -◇
<b>AR66SAK-T7.2</b> -◇
<b>AR66SAK-T10</b> -◇
<b>AR66SAK-T20</b> -◇
<b>AR66SAK-T30</b> -◇
<b>AR98SAK-T3.6</b> -◇
<b>AR98SAK-T7.2</b> -◇
<b>AR98SAK-T10</b> -◇
<b>AR98SAK-T20</b> -◇
<b>AR98SAK-T30</b> -◇

◇ TH Geared Type with Electromagnetic Brake

Product Name
-
<b>AR46SMK-T3.6</b> -◇
<b>AR46SMK-T7.2</b> -◇
<b>AR46SMK-T10</b> -◇
<b>AR46SMK-T20</b> -◇
<b>AR46SMK-T30</b> -◇
<b>AR66SMK-T3.6</b> -◇
<b>AR66SMK-T7.2</b> -◇
<b>AR66SMK-T10</b> -◇
<b>AR66SMK-T20</b> -◇
<b>AR66SMK-T30</b> -◇
<b>AR98SMK-T3.6</b> -◇
<b>AR98SMK-T7.2</b> -◇
<b>AR98SMK-T10</b> -◇
<b>AR98SMK-T20</b> -◇
<b>AR98SMK-T30</b> -◇

◇ Harmonic Geared Type

Product Name
<b>AR24SAK-H50</b> -◇
<b>AR24SAK-H100</b> -◇
<b>AR46SAK-H50</b> -◇
<b>AR46SAK-H100</b> -◇
<b>AR66SAK-H50</b> -◇
<b>AR66SAK-H100</b> -◇
<b>AR98SAK-H50</b> -◇
<b>AR98SAK-H100</b> -◇

◇ Harmonic Geared Type with Electromagnetic Brake

Product Name
-
<b>AR46SMK-H50</b> -◇
<b>AR46SMK-H100</b> -◇
<b>AR66SMK-H50</b> -◇
<b>AR66SMK-H100</b> -◇
<b>AR98SMK-H50</b> -◇
<b>AR98SMK-H100</b> -◇

● A number indicating the desired length of **1** (1 m), **2** (2 m) or **3** (3 m) for the cable included with the product is entered where the box ◇ is located within the product name. Select a desired cable length from 1 m, 2 m and 3 m.

The following items are included in each product.

Motor, Driver, Cable for Motor, Cable for Electromagnetic Brake\*, Connector for Input Signal, Connector for Output Signal, Sensor Signal Connector, Power Input Terminal Connector, Operating Manual

● The product comes with a 1 m, 2 m or 3 m cable for motor and cable for electromagnetic brake\*.

If you need cables longer than 3 m or cables offering excellent flexibility, select appropriate cables from the accessories (sold separately).

For details, refer to Page 55.

\*Only for electromagnetic brake type.

◇ PS Geared Type

Product Name
<b>AR24SAK-PS5</b> -◇
<b>AR24SAK-PS7</b> -◇
<b>AR24SAK-PS10</b> -◇
<b>AR46SAK-PS5</b> -◇
<b>AR46SAK-PS7</b> -◇
<b>AR46SAK-PS10</b> -◇
<b>AR46SAK-PS25</b> -◇
<b>AR46SAK-PS36</b> -◇
<b>AR46SAK-PS50</b> -◇
<b>AR66SAK-PS5</b> -◇
<b>AR66SAK-PS7</b> -◇
<b>AR66SAK-PS10</b> -◇
<b>AR66SAK-PS25</b> -◇
<b>AR66SAK-PS36</b> -◇
<b>AR66SAK-PS50</b> -◇
<b>AR98SAK-PS5</b> -◇
<b>AR98SAK-PS7</b> -◇
<b>AR98SAK-PS10</b> -◇
<b>AR98SAK-PS25</b> -◇
<b>AR98SAK-PS36</b> -◇
<b>AR98SAK-PS50</b> -◇

◇ PS Geared Type with Electromagnetic Brake

Product Name
-
<b>AR46SMK-PS5</b> -◇
<b>AR46SMK-PS7</b> -◇
<b>AR46SMK-PS10</b> -◇
<b>AR46SMK-PS25</b> -◇
<b>AR46SMK-PS36</b> -◇
<b>AR46SMK-PS50</b> -◇
<b>AR66SMK-PS5</b> -◇
<b>AR66SMK-PS7</b> -◇
<b>AR66SMK-PS10</b> -◇
<b>AR66SMK-PS25</b> -◇
<b>AR66SMK-PS36</b> -◇
<b>AR66SMK-PS50</b> -◇
<b>AR98SMK-PS5</b> -◇
<b>AR98SMK-PS7</b> -◇
<b>AR98SMK-PS10</b> -◇
<b>AR98SMK-PS25</b> -◇
<b>AR98SMK-PS36</b> -◇
<b>AR98SMK-PS50</b> -◇

◇ PN Geared Type

Product Name
<b>AR24SAK-N5</b> -◇
<b>AR24SAK-N7.2</b> -◇
<b>AR24SAK-N10</b> -◇
<b>AR46SAK-N5</b> -◇
<b>AR46SAK-N7.2</b> -◇
<b>AR46SAK-N10</b> -◇
<b>AR66SAK-N5</b> -◇
<b>AR66SAK-N7.2</b> -◇
<b>AR66SAK-N10</b> -◇
<b>AR66SAK-N25</b> -◇
<b>AR66SAK-N36</b> -◇
<b>AR66SAK-N50</b> -◇
<b>AR98SAK-N5</b> -◇
<b>AR98SAK-N7.2</b> -◇
<b>AR98SAK-N10</b> -◇
<b>AR98SAK-N25</b> -◇
<b>AR98SAK-N36</b> -◇
<b>AR98SAK-N50</b> -◇

◇ PN Geared Type with Electromagnetic Brake

Product Name
-
<b>AR46SMK-N5</b> -◇
<b>AR46SMK-N7.2</b> -◇
<b>AR46SMK-N10</b> -◇
<b>AR66SMK-N5</b> -◇
<b>AR66SMK-N7.2</b> -◇
<b>AR66SMK-N10</b> -◇
<b>AR66SMK-N25</b> -◇
<b>AR66SMK-N36</b> -◇
<b>AR66SMK-N50</b> -◇
<b>AR98SMK-N5</b> -◇
<b>AR98SMK-N7.2</b> -◇
<b>AR98SMK-N10</b> -◇
<b>AR98SMK-N25</b> -◇
<b>AR98SMK-N36</b> -◇
<b>AR98SMK-N50</b> -◇

The following items are included in each product.

Motor, Driver, Cable for Motor, Cable for Electromagnetic Brake\*, I/O signal Connector, Main Power Supply Input and Frame Ground Terminal Connectors, Surge Suppressor\*, Operating Manual

● The product comes with a 1 m, 2 m or 3 m cable for motor and cable for electromagnetic brake\*.

If you need cables longer than 3 m or cables offering excellent flexibility, select appropriate cables from the accessories (sold separately).

For details, refer to Page 55.

\*Only for electromagnetic brake type.

# Standard Type Frame Size 28 mm, 42 mm, 60 mm, 85 mm

## Specifications (RoHS)



Product Name	Built-in Controller	AR24S□KD-◇	AR26S□KD-◇	AR46S□KD-◇	AR66S□KD-◇	AR69S□KD-◇	AR98S□KD-◇
	Pulse Input	AR24S□K-◇	AR26S□K-◇	AR46S□K-◇	AR66S□K-◇	AR69S□K-◇	AR98S□K-◇
Max. Holding Torque	N·m	0.055	0.12	0.3	1		2
Holding Torque at Motor Standstill	While Power is Supplied	0.027	0.06	0.15	0.5		1
	Electromagnetic Brake	—	—	0.15	0.5		1
Rotor Inertial Moment	J: kg·m <sup>2</sup>	11×10 <sup>-7</sup>	20×10 <sup>-7</sup>	58×10 <sup>-7</sup> [73×10 <sup>-7</sup> ]*1	380×10 <sup>-7</sup> [500×10 <sup>-7</sup> ]*1	750×10 <sup>-7</sup> [870×10 <sup>-7</sup> ]*1	1100×10 <sup>-7</sup> [1220×10 <sup>-7</sup> ]*1
Resolution	When Set to 1000P/R	0.36/Pulse					
Power Supply Input	Voltage	24 VDC±10% (24 VDC±5%)*2		24 VDC±10% (24 VDC±5%)*2/ 48 VDC±5%	24 VDC±10% (24 VDC±5%)*2/48 VDC±5%*3		
	Input Current	A	0.9 (1.3)*2	1.4 (1.8)*2	3.1 (3.8)*2	3.0 (3.7)*2	2.5 (3.1)*2
Electromagnetic Brake*4	Power Supply Input	—		24 VDC±5%*5 0.08A	24 VDC±5%*5 0.25A		

- Either **A** (single shaft), **B** (double shaft) or **M** (electromagnetic brake) indicating the configuration is entered where the box □ is located within the product name.  
Either **A** (Single shaft) or **B** (Double shaft) indicating the configuration is entered in the box where □ is located within the **AR24** and **AR26** product names.  
A number indicating the desired length of **1** (1 m), **2** (2 m) or **3** (3 m) for the cable included with the product is entered where the box ◇ is located within the product name.
- \*1 The brackets [ ] indicate the specifications for the electromagnetic brake type.
- \*2 The parentheses ( ) indicate the specifications for the built-in controller type.
- \*3 When the motor is operated from 48 VDC input, use an inertial load 10 times the rotor inertial ratio or less and twice the safety factor or more when calculating the acceleration torque.
- \*4 For the pulse input type, a separate power supply for the electromagnetic brake is also required.
- \*5 If the wiring distance between the motor and driver is extended to 20 m or longer using an accessory cable (sold separately), the 24 VDC±4% specification applies.

## Speed – Torque Characteristics

**AR24**

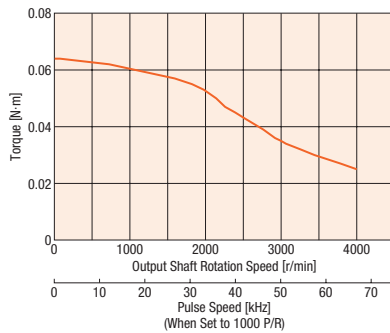

**AR26**

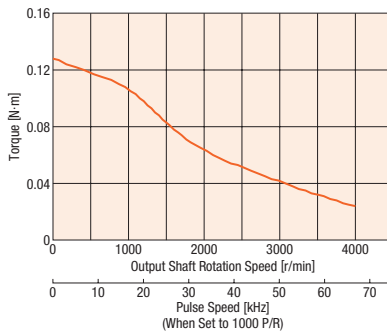

**AR46**

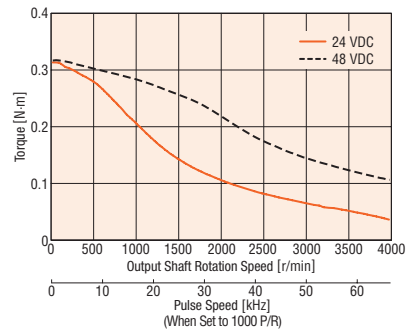

**AR66**

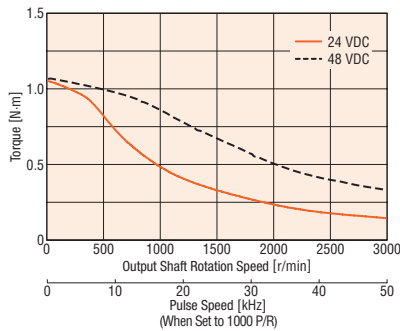

**AR69**

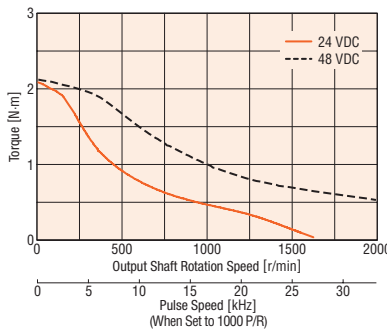

**AR98**

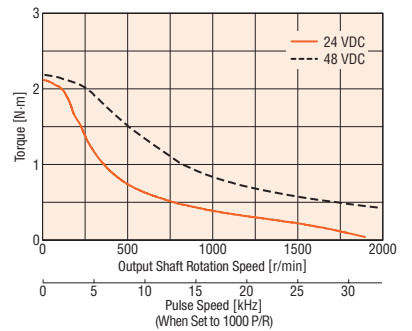

### Note

- Depending on the driving conditions, a considerable amount of heat may be generated by the motor. Be sure to keep the temperature of the motor case at approximately 100°C max.

# TH Geared Type Frame Size 28 mm

## Specifications RoHS



Product Name	Built-in Controller	AR24SAKD-T7.2-◇	AR24SAKD-T10-◇	AR24SAKD-T20-◇	AR24SAKD-T30-◇
	Pulse Input	AR24SAK-T7.2-◇	AR24SAK-T10-◇	AR24SAK-T20-◇	AR24SAK-T30-◇
Max. Holding Torque	N·m	0.2	0.3	0.4	0.5
Rotor Inertial Moment	J: kg·m <sup>2</sup>	$11 \times 10^{-7}$			
Gear Ratio		7.2	10	20	30
Resolution	When Set to 1000P/R	0.05°/Pulse	0.036°/Pulse	0.018°/Pulse	0.012°/Pulse
Permissible Torque	N·m	0.2	0.3	0.4	0.5
Holding Torque at Motor Standstill While Power is Supplied	N·m	0.13	0.19	0.38	0.5
Permissible Speed Range	r/min	0~416	0~300	0~150	0~100
Backlash	arc minute (degrees)	60(1°)			
Power Supply Input	Voltage	24 VDC±10% (24 VDC±5%)*			
	Input Current	A 0.9(1.3)*			

● A number indicating the desired length of **1** (1 m), **2** (2 m) or **3** (3 m) for the cable included with the product is entered where the box ◇ is located within the product name.

\*The parentheses () indicate the specifications for the built-in controller type.

## Speed – Torque Characteristics

**AR24 Gear Ratio 7.2**

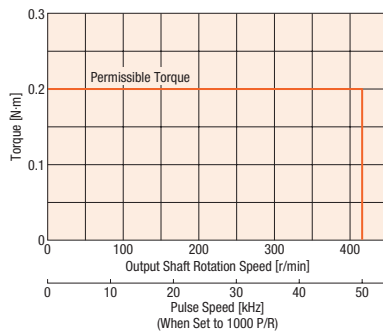

**AR24 Gear Ratio 10**

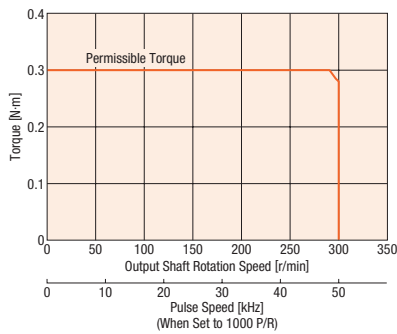

**AR24 Gear Ratio 20**

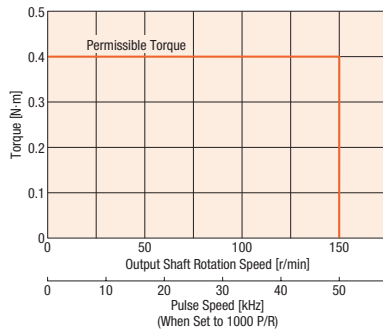

**AR24 Gear Ratio 30**

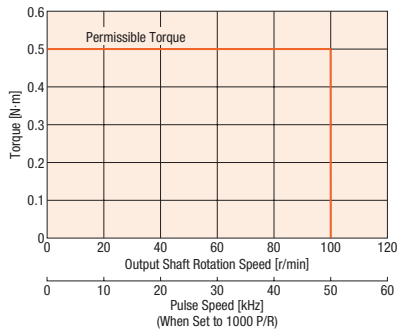

### Note

● Depending on the driving conditions, a considerable amount of heat may be generated by the motor. Be sure to keep the temperature of the motor case at approximately 100°C max.

Features

Lineup

System Configuration

Product Line

Specifications and Characteristics

Dimension

Connection and Operation

Combination List

Extended Functions

How to Read Specifications and Characteristics

Accessory

Controller

# TH Geared Type Frame Size 42 mm

## Specifications RoHS



Product Name	Built-in Controller	AR46S□KD-T3.6-◇	AR46S□KD-T7.2-◇	AR46S□KD-T10-◇	AR46S□KD-T20-◇	AR46S□KD-T30-◇
	Pulse Input	AR46S□K-T3.6-◇	AR46S□K-T7.2-◇	AR46S□K-T10-◇	AR46S□K-T20-◇	AR46S□K-T30-◇
Max. Holding Torque	N·m	0.35	0.7	1	1.5	
Rotor Inertial Moment	J: kg·m <sup>2</sup>	$58 \times 10^{-7} [73 \times 10^{-7}]^{*1}$				
Gear Ratio		3.6	7.2	10	20	30
Resolution	When Set to 1000P/R	0.1°/Pulse	0.05°/Pulse	0.036°/Pulse	0.018°/Pulse	0.012°/Pulse
Permissible Torque	N·m	0.35	0.7	1	1.5	
Holding Torque at Motor Standstill	While Power is Supplied N·m Electromagnetic Brake N·m	0.33 0.33	0.67 0.67	0.93 0.93	1.5 1.5	
Permissible Speed Range	r/min	0~500	0~250	0~180	0~90	0~60
Backlash	arc minute (degrees)	45(0.75°)	25 (0.42°)		15 (0.25°)	
Power Supply Input	Voltage	24 VDC±10% (24 VDC±5%)*2/48 VDC±5%				
	Input Current	1.4 (1.8)*2				
Electromagnetic Brake*3	Power Supply Input	24 VDC±5%*4 0.08 A				

● Either **A** (single shaft) or **M** (electromagnetic brake) indicating the configuration is entered where the box □ is located within the product name.

A number indicating the desired length of **1** (1 m), **2** (2 m) or **3** (3 m) for the cable included with the product is entered where the box ◇ is located within the product name.

\*1 The brackets [ ] indicate the specifications for the electromagnetic brake type.

\*2 The parentheses ( ) indicate the specifications for the built-in controller type.

\*3 For the pulse input type, a separate power supply for the electromagnetic brake is also required.

\*4 If the wiring distance between the motor and driver is extended to 20 m or longer using an accessory cable (sold separately), the 24 VDC±4% specification applies.

## Speed – Torque Characteristics

**AR46 Gear Ratio 3.6**

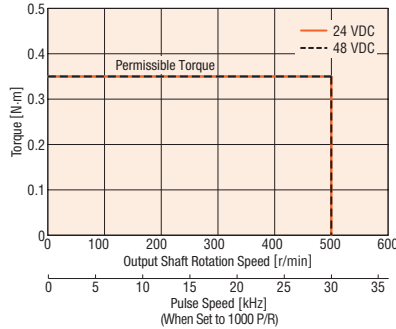

**AR46 Gear Ratio 7.2**

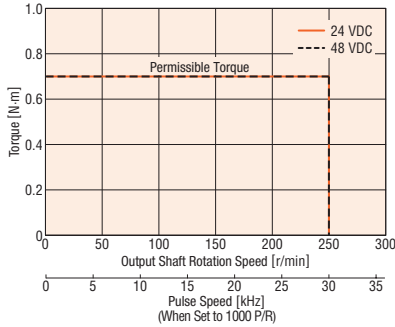

**AR46 Gear Ratio 10**

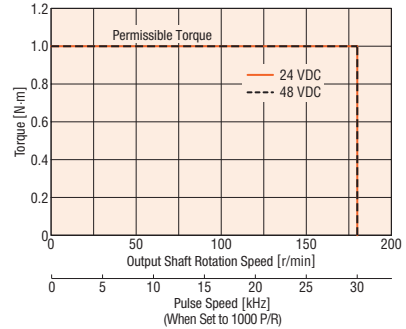

**AR46 Gear Ratio 20**

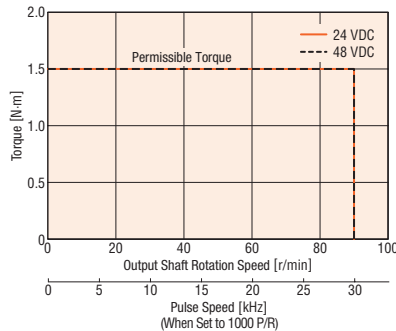

**AR46 Gear Ratio 30**

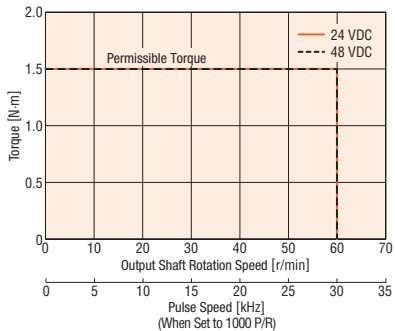

### Note

● Depending on the driving conditions, a considerable amount of heat may be generated by the motor. Be sure to keep the temperature of the motor case at approximately 100°C max.

# TH Geared Type Frame Size 60 mm

## Specifications RoHS



Product Name	Built-in Controller	AR66S□KD-T3.6-◇	AR66S□KD-T7.2-◇	AR66S□KD-T10-◇	AR66S□KD-T20-◇	AR66S□KD-T30-◇
	Pulse Input	AR66S□K-T3.6-◇	AR66S□K-T7.2-◇	AR66S□K-T10-◇	AR66S□K-T20-◇	AR66S□K-T30-◇
Max. Holding Torque	N·m	1.25	2.5	3	3.5	4
Rotor Inertial Moment	J: kg·m <sup>2</sup>	$380 \times 10^{-7} [500 \times 10^{-7}]^{*1}$				
Gear Ratio		3.6	7.2	10	20	30
Resolution	When Set to 1000P/R	0.1°/Pulse	0.05°/Pulse	0.036°/Pulse	0.018°/Pulse	0.012°/Pulse
Permissible Torque	N·m	1.25	2.5	3	3.5	4
Holding Torque at	While Power is Supplied N·m	1.1	2.2	3	3.5	4
Motor Standstill	Electromagnetic Brake N·m	1.1	2.2	3	3.5	4
Permissible Speed Range	r/min	0~500	0~250	0~180	0~90	0~60
Backlash	arc minute (degrees)	35 (0.59°)	15 (0.25°)		10 (0.17°)	
Power Supply Input	Voltage	24 VDC±10% (24 VDC±5%)*2/48 VDC±5%*3				
	Input Current	3.1(3.8)*2				
Electromagnetic Brake*4	Power Supply Input	24 VDC±5%*5 0.25 A				

- Either **A** (single shaft) or **M** (electromagnetic brake) indicating the configuration is entered where the box □ is located within the product name.
- A number indicating the desired length of **1** (1 m), **2** (2 m) or **3** (3 m) for the cable included with the product is entered where the box ◇ is located within the product name.
- \*1 The brackets [ ] indicate the specifications for the electromagnetic brake type.
- \*2 The parentheses ( ) indicate the specifications for the built-in controller type.
- \*3 When the motor is operated from 48 VDC input, use an inertial load 10 times the rotor inertial ratio or less and twice the safety factor or more when calculating the acceleration torque.
- \*4 For the pulse input type, a separate power supply for the electromagnetic brake is also required.
- \*5 If the wiring distance between the motor and driver is extended to 20 m or longer using an accessory cable (sold separately), the 24 VDC±4% specification applies.

## Speed – Torque Characteristics

**AR66 Gear Ratio 3.6**

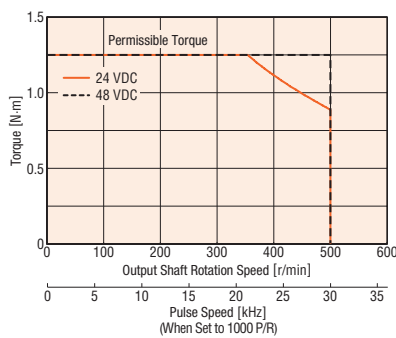

**AR66 Gear Ratio 7.2**

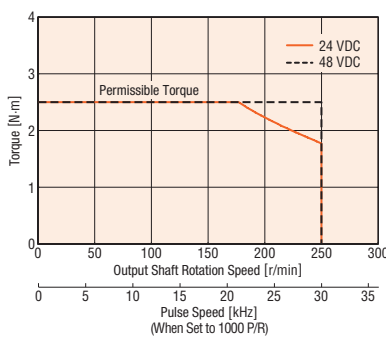

**AR66 Gear Ratio 10**

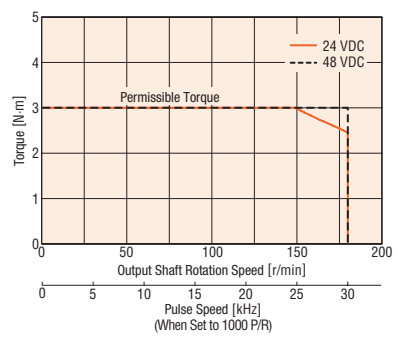

**AR66 Gear Ratio 20**

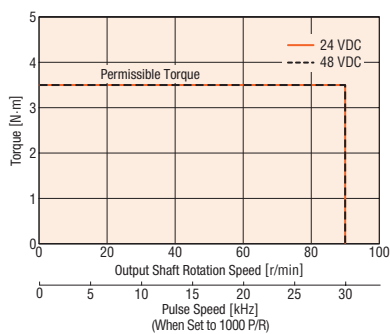

**AR66 Gear Ratio 30**

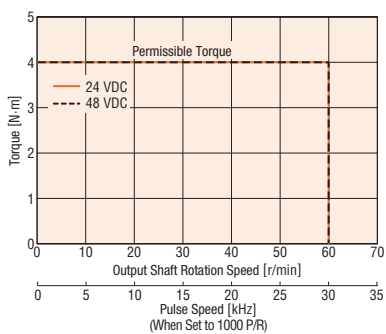

### Note

- Depending on the driving conditions, a considerable amount of heat may be generated by the motor. Be sure to keep the temperature of the motor case at approximately 100°C max.

Features

Lineup

System Configuration

Product Line

Specifications and Characteristics

Dimension

Connection and Operation

Combination List

Extended Functions

How to Read Specifications and Characteristics

Accessory

Controller

# TH Geared Type Frame Size 90 mm

## Specifications RoHS



Product Name	Built-in Controller	AR98S□KD-T3.6-◇	AR98S□KD-T7.2-◇	AR98S□KD-T10-◇	AR98S□KD-T20-◇	AR98S□KD-T30-◇
	Pulse Input	AR98S□K-T3.6-◇	AR98S□K-T7.2-◇	AR98S□K-T10-◇	AR98S□K-T20-◇	AR98S□K-T30-◇
Max. Holding Torque	N·m	4.5	9	12		
Rotor Inertial Moment	J: kg·m <sup>2</sup>	1100×10 <sup>-7</sup> [1220×10 <sup>-7</sup> ]*1				
Gear Ratio		3.6	7.2	10	20	30
Resolution	When Set to 1000P/R	0.1°/Pulse	0.05°/Pulse	0.036°/Pulse	0.018°/Pulse	0.012°/Pulse
Permissible Torque	N·m	4.5	9	12		
Holding Torque at Motor Standstill	While Power is Supplied N·m	3.6	7.2	9	12	
	Electromagnetic Brake N·m	3.6	7.2	9	12	
Permissible Speed Range	r/min	0~500	0~250	0~180	0~90	0~60
Backlash	arc minute (degrees)	25 (0.42°)	15 (0.25°)		10 (0.17°)	
Power Supply Input	Voltage	24 VDC±10% (24 VDC±5%)*2/48 VDC±5%*3				
	Input Current	A 2.5(3.1)*2				
Electromagnetic Brake*4	Power Supply Input	24 VDC±5%*5 0.25 A				

- Either **A** (single shaft) or **M** (electromagnetic brake) indicating the configuration is entered where the box □ is located within the product name.
- A number indicating the desired length of **1** (1 m), **2** (2 m) or **3** (3 m) for the cable included with the product is entered where the box ◇ is located within the product name.
- \*1 The brackets [ ] indicate the specifications for the electromagnetic brake type.
- \*2 The parentheses ( ) indicate the specifications for the built-in controller type.
- \*3 When the motor is operated from 48 VDC input, use an inertial load 10 times the rotor inertial ratio or less and twice the safety factor or more when calculating the acceleration torque.
- \*4 For the pulse input type, a separate power supply for the electromagnetic brake is also required.
- \*5 If the wiring distance between the motor and driver is extended to 20 m or longer using an accessory cable (sold separately), the 24 VDC±4% specification applies.

## Speed – Torque Characteristics

AR98 Gear Ratio 3.6

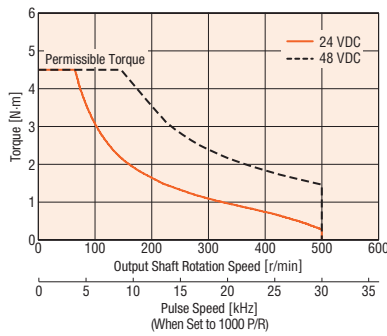

AR98 Gear Ratio 7.2

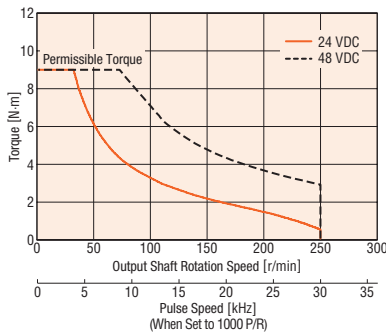

AR98 Gear Ratio 10

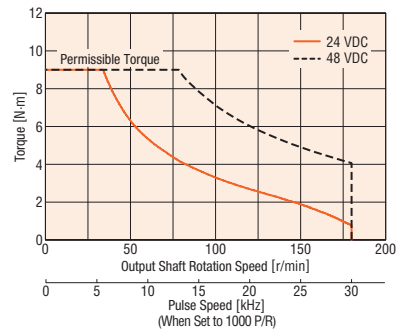

AR98 Gear Ratio 20

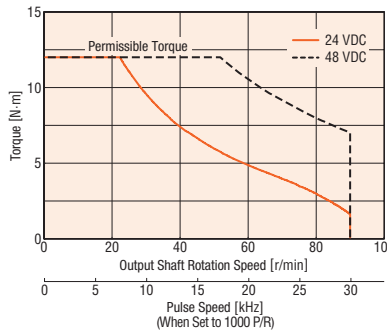

AR98 Gear Ratio 30

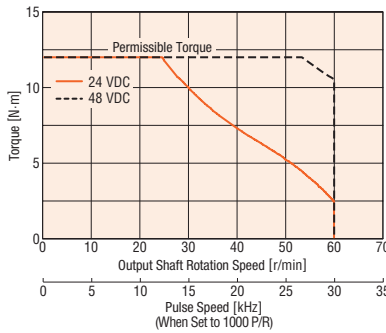

### Note

- Depending on the driving conditions, a considerable amount of heat may be generated by the motor. Be sure to keep the temperature of the motor case at approximately 100°C max.

# PS Geared Type Frame Size 28 mm

## Specifications RoHS



Product Name	Built-in Controller	AR24SAKD-PS5-◇	AR24SAKD-PS7-◇	AR24SAKD-PS10-◇
	Pulse Input	AR24SAK-PS5-◇	AR24SAK-PS7-◇	AR24SAK-PS10-◇
Max. Holding Torque	N·m	0.2	0.3	0.5
Rotor Inertial Moment	J: kg·m <sup>2</sup>		$11 \times 10^{-7}$	
Gear Ratio		5	7.2	10
Resolution	When Set to 1000P/R	0.072°/Pulse	0.05°/Pulse	0.036°/Pulse
Permissible Torque	N·m	0.2	0.3	0.5
Maximum Torque	N·m		0.5	
Holding Torque at Motor Standstill	While Power is Supplied N·m	0.13	0.19	0.27
Permissible Speed Range	r/min	0~600	0~416	0~300
Backlash	arc minute (degrees)		35 (0.59°)	
Power Supply Input	Voltage	24 VDC±10% (24 VDC±5%)*		
	Input Current	0.9(1.3)*		

● A number indicating the desired length of **1** (1 m), **2** (2 m) or **3** (3 m) for the cable included with the product is entered where the box ◇ is located within the product name.  
 \*The parentheses () indicate the specifications for the built-in controller type.

## Speed – Torque Characteristics

**AR24 Gear Ratio 5**

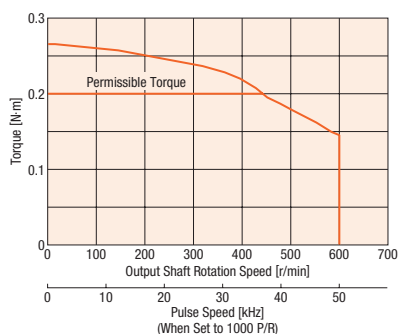

**AR24 Gear Ratio 7.2**

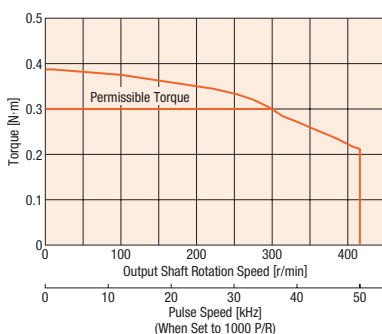

**AR24 Gear Ratio 10**

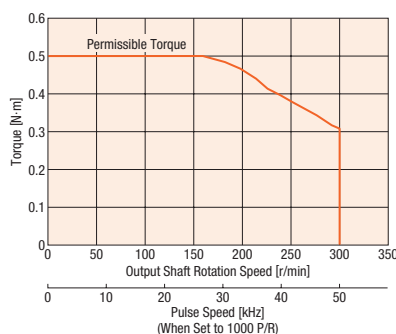

### Note

● Depending on the driving conditions, a considerable amount of heat may be generated by the motor. Be sure to keep the temperature of the motor case at approximately 100°C max.

Features

Lineup

System Configuration

Product Line

Specifications and Characteristics

Dimension

Connection and Operation

Combination List

Extended Functions

How to Read Specifications and Characteristics

Accessory

Controller

# PS Geared Type Frame Size 42 mm

## Specifications RoHS



Product Name	Built-in Controller	AR46S□KD-PS5-◇	AR46S□KD-PS7-◇	AR46S□KD-PS10-◇	AR46S□KD-PS25-◇	AR46S□KD-PS36-◇	AR46S□KD-PS50-◇
	Pulse Input	AR46S□K-PS5-◇	AR46S□K-PS7-◇	AR46S□K-PS10-◇	AR46S□K-PS25-◇	AR46S□K-PS36-◇	AR46S□K-PS50-◇
Max. Holding Torque	N·m	1	1.5	2.5	2.5	3	3
Rotor Inertial Moment	J: kg·m <sup>2</sup>	$58 \times 10^{-7} [73 \times 10^{-7}]^{*1}$					
Gear Ratio		5	7.2	10	25	36	50
Resolution	When Set to 1000P/R	0.072°/Pulse	0.05°/Pulse	0.036°/Pulse	0.0144°/Pulse	0.01°/Pulse	0.0072°/Pulse
Permissible Torque	N·m	1	1.5	2.5	2.5	3	3
Maximum Torque	N·m	1.5	2	2.5	2.5	6	3
Holding Torque at Motor Standstill	While Power is Supplied N·m Electromagnetic Brake N·m	0.75 0.75	1 1	1.5 1.5	2.5 2.5	3 3	3 3
Permissible Speed Range	r/min	0~600	0~416	0~300	0~120	0~83	0~60
Backlash	arc minute (degrees)	25 (0.42°)					
Power Supply Input	Voltage	24 VDC±10% (24 VDC±5%)*2/48 VDC±5%					
	Input Current	1.4(1.8)*2					
Electromagnetic Brake*3	Power Supply Input	24 VDC±5%*4 0.08 A					

● Either **A** (single shaft) or **M** (electromagnetic brake) indicating the configuration is entered where the box □ is located within the product name.

A number indicating the desired length of **1** (1 m), **2** (2 m) or **3** (3 m) for the cable included with the product is entered where the box ◇ is located within the product name.

\*1 The brackets [ ] indicate the specifications for the electromagnetic brake type.

\*2 The parentheses ( ) indicate the specifications for the built-in controller type.

\*3 For the pulse input type, a separate power supply for the electromagnetic brake is also required.

\*4 If the wiring distance between the motor and driver is extended to 20 m or longer using an accessory cable (sold separately), the 24 VDC±4% specification applies.

## Speed – Torque Characteristics

**AR46 Gear Ratio 5**

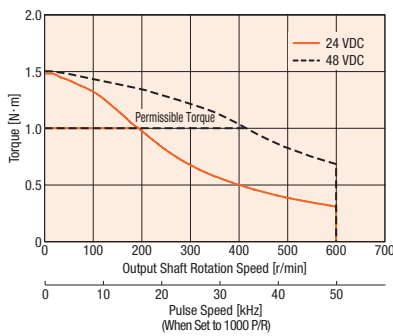

**AR46 Gear Ratio 7.2**

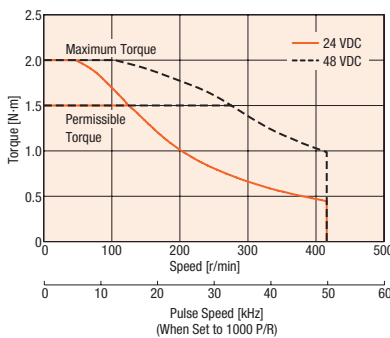

**AR46 Gear Ratio 10**

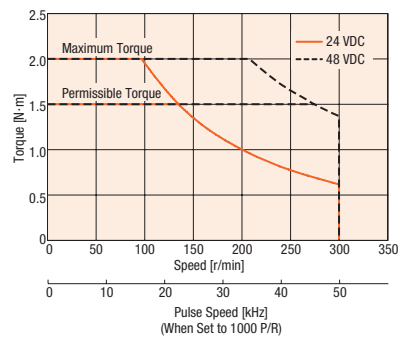

**AR46 Gear Ratio 25**

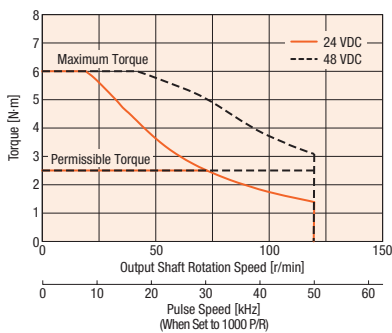

**AR46 Gear Ratio 36**

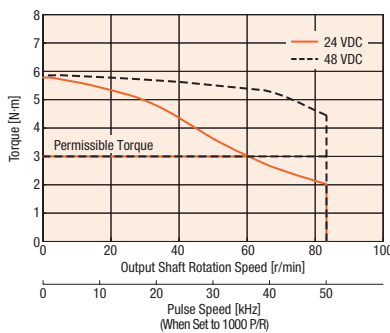

**AR46 Gear Ratio 50**

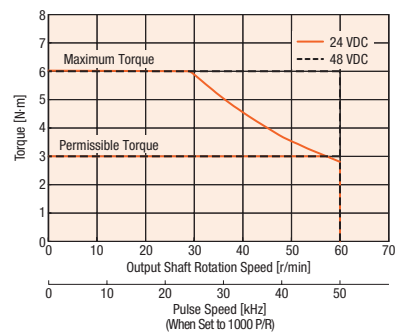

### Note

● Depending on the driving conditions, a considerable amount of heat may be generated by the motor. Be sure to keep the temperature of the motor case at approximately 100°C max.

# PS Geared Type Frame Size 60 mm

## Specifications RoHS



Product Name	Built-in Controller	AR66S□KD-PS5-◇	AR66S□KD-PS7-◇	AR66S□KD-PS10-◇	AR66S□KD-PS25-◇	AR66S□KD-PS36-◇	AR66S□KD-PS50-◇
	Pulse Input	AR66S□K-PS5-◇	AR66S□K-PS7-◇	AR66S□K-PS10-◇	AR66S□K-PS25-◇	AR66S□K-PS36-◇	AR66S□K-PS50-◇
Max. Holding Torque	N·m	3.5	4	5	8		
Rotor Inertial Moment	J: kg·m <sup>2</sup>	380×10 <sup>-7</sup> [500×10 <sup>-7</sup> ]*1					
Gear Ratio		5	7.2	10	25	36	50
Resolution	When Set to 1000P/R	0.072°/Pulse	0.05°/Pulse	0.036°/Pulse	0.0144°/Pulse	0.01°/Pulse	0.0072°/Pulse
Permissible Torque		3.5	4	5	8		
Maximum Torque	N·m	7	9	11	16	20	
Holding Torque at	While Power is Supplied N·m	2.5	3.6	5	7.6	8	
Motor Standstill	Electromagnetic Brake N·m	2.5	3.6	5	7.6	8	
Permissible Speed Range	r/min	0~600	0~416	0~300	0~120	0~83	0~60
Backlash	arc minute (degrees)	15 (0.25°)					
Power Supply Input	Voltage	24 VDC±10% (24 VDC±5%)*2/48 VDC±5%*3					
	Input Current	3.1(3.8)*2					
Electromagnetic Brake*4	Power Supply Input	24 VDC±5%*5 0.25 A					

● Either **A** (single shaft) or **M** (electromagnetic brake) indicating the configuration is entered where the box □ is located within the product name.

A number indicating the desired length of **1** (1 m), **2** (2 m) or **3** (3 m) for the cable included with the product is entered where the box ◇ is located within the product name.

\*1 The brackets [ ] indicate the specifications for the electromagnetic brake type.

\*2 The parentheses ( ) indicate the specifications for the built-in controller type.

\*3 When the motor is operated from 48 VDC input, use an inertial load 10 times the rotor inertial ratio or less and twice the safety factor or more when calculating the acceleration torque.

\*4 For the pulse input type, a separate power supply for the electromagnetic brake is also required.

\*5 If the wiring distance between the motor and driver is extended to 20 m or longer using an accessory cable (sold separately), the 24 VDC±4% specification applies.

## Speed – Torque Characteristics

**AR66 Gear Ratio 5**

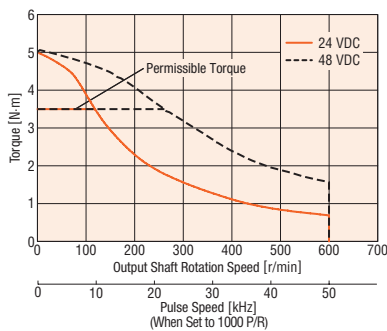

**AR66 Gear Ratio 7.2**

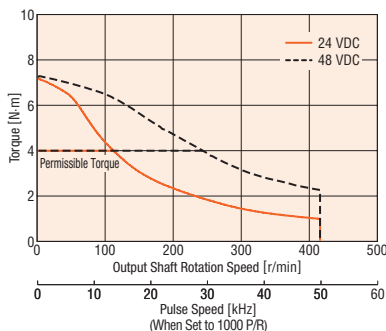

**AR66 Gear Ratio 10**

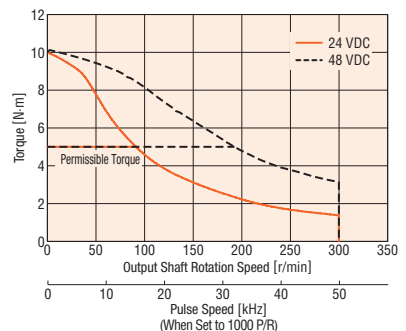

**AR66 Gear Ratio 25**

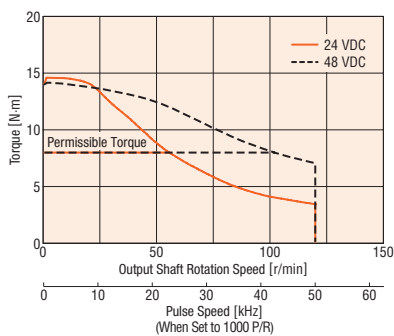

**AR66 Gear Ratio 36**

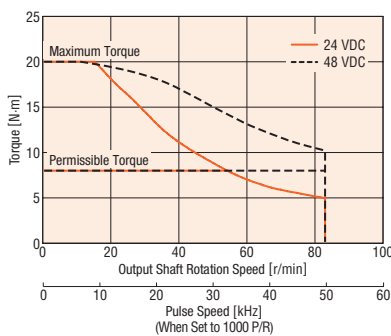

**AR66 Gear Ratio 50**

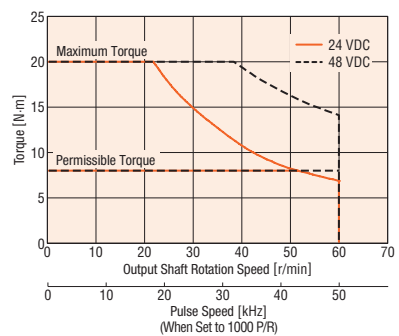

### Note

● Depending on the driving conditions, a considerable amount of heat may be generated by the motor. Be sure to keep the temperature of the motor case at approximately 100°C max.

Features

Lineup

System Configuration

Product Line

Specifications and Characteristics

Dimension

Connection and Operation

Combination List

Extended Functions

How to Read Specifications and Characteristics

Accessory

Controller

# PS Geared Type Frame Size 90 mm

## Specifications RoHS



Product Name	Built-in Controller	AR98□KD-PS5-◇	AR98□KD-PS7-◇	AR98□KD-PS10-◇	AR98□KD-PS25-◇	AR98□KD-PS36-◇	AR98□KD-PS50-◇
	Pulse Input	AR98□K-PS5-◇	AR98□K-PS7-◇	AR98□K-PS10-◇	AR98□K-PS25-◇	AR98□K-PS36-◇	AR98□K-PS50-◇
Max. Holding Torque	N·m	10	14	20	37		
Rotor Inertial Moment	J: kg·m <sup>2</sup>	1100×10 <sup>-7</sup> [1220×10 <sup>-7</sup> ]*1					
Gear Ratio		5	7.2	10	25	36	50
Resolution	When Set to 1000P/R	0.072°/Pulse	0.05°/Pulse	0.036°/Pulse	0.0144°/Pulse	0.01°/Pulse	0.0072°/Pulse
Permissible Torque	N·m	10	14	20	37		
Maximum Torque	N·m	28	35		56	60	
Holding Torque at Motor Standstill	While Power is Supplied N·m Electromagnetic Brake N·m	5 5	7.2 7.2	10 10	25 25	36 36	37 37
Permissible Speed Range	r/min	0~400	0~277	0~200	0~80	0~55	0~40
Backlash	arc minute (degrees)	15 (0.25°)					
Power Supply Input	Voltage	24 VDC±10% (24 VDC±5%)*2/48 VDC±5%*3					
	Input Current	2.5(3.1)*2					
Electromagnetic Brake*4	Power Supply Input	24 VDC±5%*5 0.25 A					

● Either **A** (single shaft) or **M** (electromagnetic brake) indicating the configuration is entered where the box □ is located within the product name.

A number indicating the desired length of **1** (1 m), **2** (2 m) or **3** (3 m) for the cable included with the product is entered where the box ◇ is located within the product name.

\*1 The brackets [ ] indicate the specifications for the electromagnetic brake type.

\*2 The parentheses () indicate the specifications for the built-in controller type.

\*3 When the motor is operated from 48 VDC input, use an inertial load 10 times the rotor inertial ratio or less and twice the safety factor or more when calculating the acceleration torque.

\*4 For the pulse input type, a separate power supply for the electromagnetic brake is also required.

\*5 If the wiring distance between the motor and driver is extended to 20 m or longer using an accessory cable (sold separately), the 24 VDC±4% specification applies.

## Speed – Torque Characteristics

### AR98 Gear Ratio 5

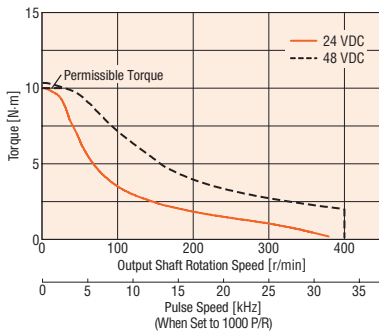

### AR98 Gear Ratio 7.2

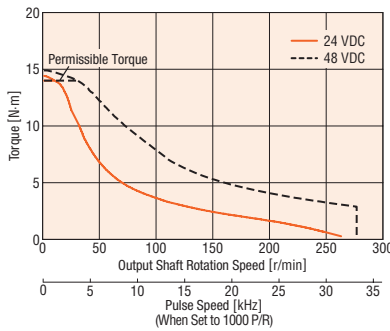

### AR98 Gear Ratio 10

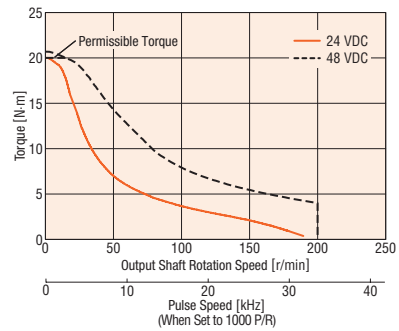

### AR98 Gear Ratio 25

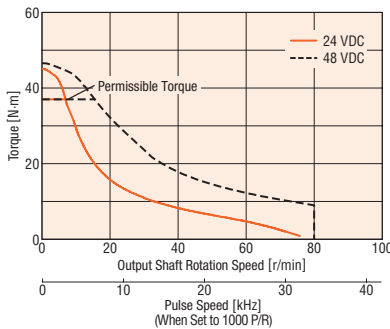

### AR98 Gear Ratio 36

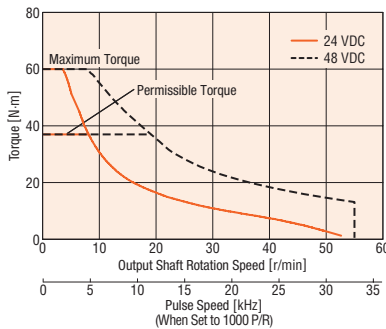

### AR98 Gear Ratio 50

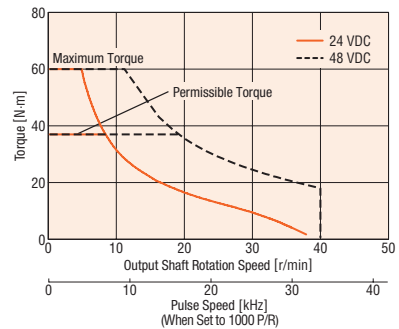

### Note

● Depending on the driving conditions, a considerable amount of heat may be generated by the motor. Be sure to keep the temperature of the motor case at approximately 100°C max.

# PN Geared Type Frame Size 28 mm

## Specifications RoHS



Product Name	Built-in Controller Pulse Input	AR24SAKD-N5-◇	AR24SAKD-N7.2-◇	AR24SAKD-N10-◇
		AR24SAK-N5-◇	AR24SAK-N7.2-◇	AR24SAK-N10-◇
Max. Holding Torque	N·m	0.2	0.3	0.5
Rotor Inertial Moment	J: kg·m <sup>2</sup>	$11 \times 10^{-7}$		
Gear Ratio		5	7.2	10
Resolution	When Set to 1000P/R	0.072°/Pulse	0.05°/Pulse	0.036°/Pulse
Permissible Torque	N·m	0.2	0.3	0.5
Maximum Torque	N·m	0.5		
Holding Torque at Motor Standstill	While Power is Supplied N·m	0.13	0.19	0.27
Permissible Speed Range	r/min	0~600	0~416	0~300
Backlash	arc minute (degrees)	3(0.05°)		
Power Supply Input	Voltage	24 VDC±10% (24 VDC±5%)*		
	Input Current	0.9(1.3)*		

● A number indicating the desired length of **1** (1 m), **2** (2 m) or **3** (3 m) for the cable included with the product is entered where the box ◇ is located within the product name.

\* The parentheses () indicate the specifications for the built-in controller type.

## Speed – Torque Characteristics

**AR24 Gear Ratio 5**

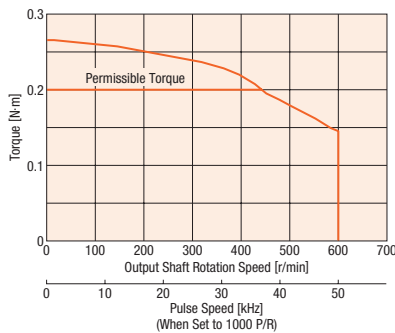

**AR24 Gear Ratio 7.2**

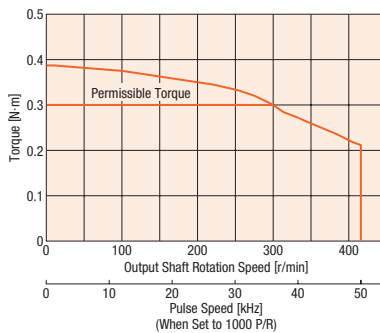

**AR24 Gear Ratio 10**

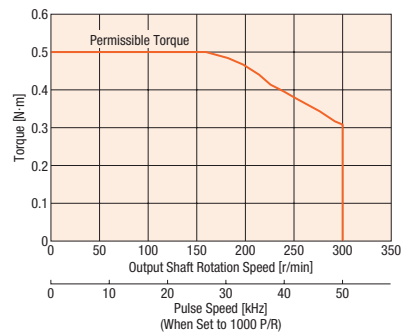

### Note

● Depending on the driving conditions, a considerable amount of heat may be generated by the motor. Be sure to keep the temperature of the motor case at approximately 100°C max.

Features

Lineup

System Configuration

Product Line

Specifications and Characteristics

Dimension

Connection and Operation

Combination List

Extended Functions

How to Read Specifications and Characteristics

Accessory

Controller

# PN Geared Type Frame Size 42 mm

## Specifications RoHS



Product Name	Built-in Controller	<b>AR46S</b> □ <b>KD-N5</b> -◇	<b>AR46S</b> □ <b>KD-N7.2</b> -◇	<b>AR46S</b> □ <b>KD-N10</b> -◇
	Pulse Input	<b>AR46S</b> □ <b>K-N5</b> -◇	<b>AR46S</b> □ <b>K-N7.2</b> -◇	<b>AR46S</b> □ <b>K-N10</b> -◇
Max. Holding Torque	N·m	1.35	1.5	
Rotor Inertial Moment	J: kg·m <sup>2</sup>	58×10 <sup>-7</sup> [73×10 <sup>-7</sup> ]*1		
Gear Ratio		5	7.2	10
Resolution	When Set to 1000P/R	0.072°/Pulse	0.05°/Pulse	0.036°/Pulse
Permissible Torque	N·m	1.35	1.5	
Maximum Torque	N·m	1.5	2	
Holding Torque at	While Power is Supplied N·m	0.75	1	1.5
Motor Standstill	Electromagnetic Brake N·m	0.75	1	1.5
Permissible Speed Range	r/min	0~600	0~416	0~300
Backlash	arc minute (degrees)	2(0.034°)		
Power Supply Input	Voltage	24 VDC±10% (24 VDC±5%)*2/48 VDC±5%		
	Input Current	1.4(1.8)*2		
Electromagnetic Brake*3	Power Supply Input	24 VDC±5%*4 0.08 A		

- Either **A** (single shaft) or **M** (electromagnetic brake) indicating the configuration is entered where the box □ is located within the product name.  
A number indicating the desired length of **1** (1 m), **2** (2 m) or **3** (3 m) for the cable included with the product is entered where the box ◇ is located within the product name.
- \*1 The brackets [ ] indicate the specifications for the electromagnetic brake type.
- \*2 The parentheses ( ) indicate the specifications for the built-in controller type.
- \*3 For the pulse input type, a separate power supply for the electromagnetic brake is also required.
- \*4 If the wiring distance between the motor and driver is extended to 20 m or longer using an accessory cable (sold separately), the 24 VDC±4% specification applies.

## Speed – Torque Characteristics

**AR46 Gear Ratio 5**

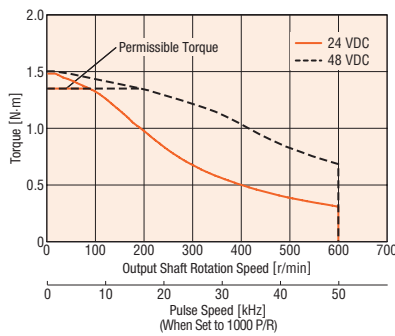

**AR46 Gear Ratio 7.2**

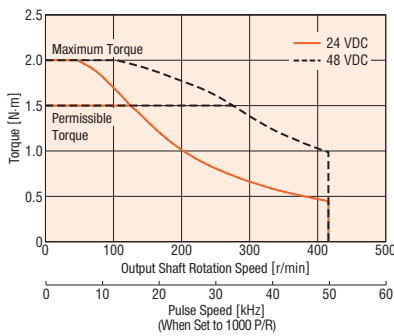

**AR46 Gear Ratio 10**

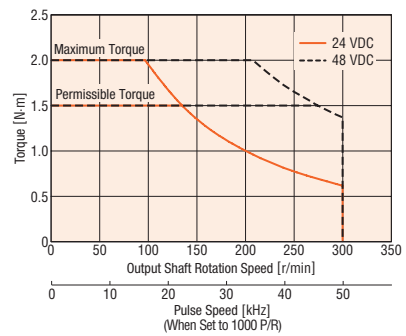

### Note

- Depending on the driving conditions, a considerable amount of heat may be generated by the motor. Be sure to keep the temperature of the motor case at approximately 100°C max.

# PN Geared Type Frame Size 60 mm

## Specifications RoHS



Product Name	Built-in Controller	AR66S□KD-N5-◇	AR66S□KD-N7.2-◇	AR66S□KD-N10-◇	AR66S□KD-N25-◇	AR66S□KD-N36-◇	AR66S□KD-N50-◇
	Pulse Input	AR66S□K-N5-◇	AR66S□K-N7.2-◇	AR66S□K-N10-◇	AR66S□K-N25-◇	AR66S□K-N36-◇	AR66S□K-N50-◇
Max. Holding Torque	N·m	3.5	4	5	8		
Rotor Inertial Moment	J: kg·m <sup>2</sup>	$380 \times 10^{-7} [500 \times 10^{-7}]^{*1}$					
Gear Ratio		5	7.2	10	25	36	50
Resolution	When Set to 1000P/R	0.072°/Pulse	0.05°/Pulse	0.036°/Pulse	0.0144°/Pulse	0.01°/Pulse	0.0072°/Pulse
Permissible Torque	N·m	3.5	4	5	8		
Maximum Torque	N·m	7	9	11	16	20	
Holding Torque at Motor Standstill	While Power is Supplied N·m	2.5	3.6	5	7.6	8	
	Electromagnetic Brake N·m	2.5	3.6	5	7.6	8	
Permissible Speed Range	r/min	0~600	0~416	0~300	0~120	0~83	0~60
Backlash	arc minute (degrees)	2(0.034°)			3(0.05°)		
Power Supply Input	Voltage	24 VDC±10% (24 VDC±5%)*2/48 VDC±5%*3					
	Input Current	A					
Electromagnetic Brake*4	Power Supply Input	24 VDC±5%*5 0.25 A					

- Either **A** (single shaft) or **M** (electromagnetic brake) indicating the configuration is entered where the box □ is located within the product name.  
A number indicating the desired length of **1** (1 m), **2** (2 m) or **3** (3 m) for the cable included with the product is entered where the box ◇ is located within the product name.
- \*1 The brackets [ ] indicate the specifications for the electromagnetic brake type.
- \*2 The parentheses ( ) indicate the specifications for the built-in controller type.
- \*3 When the motor is operated from 48 VDC input, use an inertial load 10 times the rotor inertial ratio or less and twice the safety factor or more when calculating the acceleration torque.
- \*4 For the pulse input type, a separate power supply for the electromagnetic brake is also required.
- \*5 If the wiring distance between the motor and driver is extended to 20 m or longer using an accessory cable (sold separately), the 24 VDC±4% specification applies.

## Speed – Torque Characteristics

AR66 Gear Ratio 5

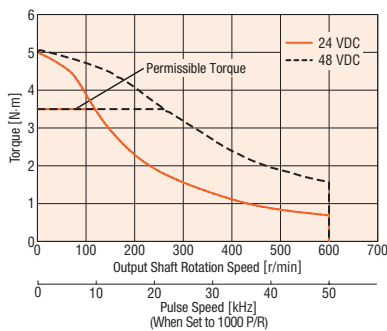

AR66 Gear Ratio 7.2

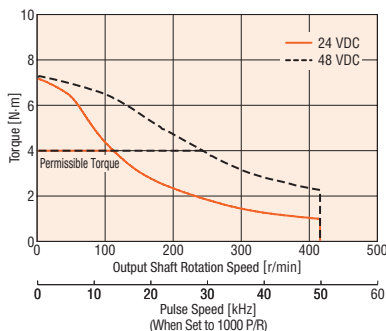

AR66 Gear Ratio 10

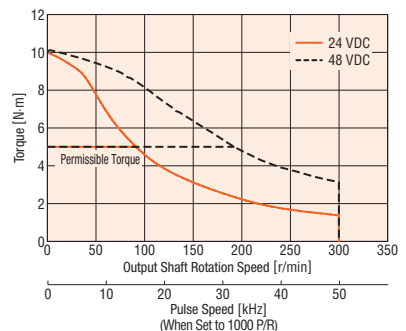

AR66 Gear Ratio 25

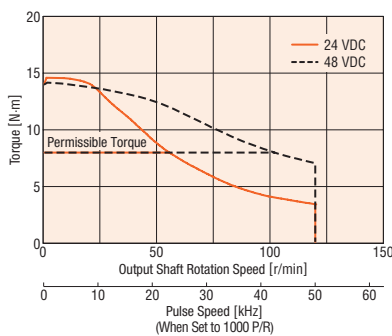

AR66 Gear Ratio 36

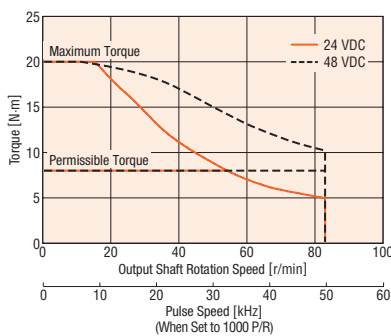

AR66 Gear Ratio 50

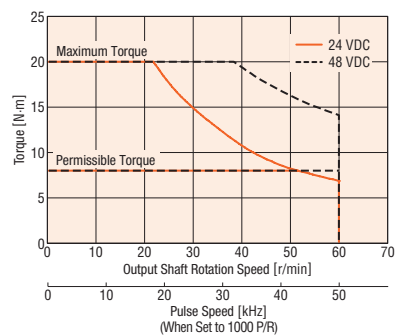

### Note

- Depending on the driving conditions, a considerable amount of heat may be generated by the motor. Be sure to keep the temperature of the motor case at approximately 100°C max.

Features

Lineup

System Configuration

Product Line

Specifications and Characteristics

Dimension

Connection and Operation

Combination List

Extended Functions

How to Read Specifications and Characteristics

Accessory

Controller

# PN Geared Type Frame Size 90 mm

## Specifications (RoHS)



Product Name	Built-in Controller	AR98S□KD-N5-◇	AR98S□KD-N7.2-◇	AR98S□KD-N10-◇	AR98S□KD-N25-◇	AR98S□KD-N36-◇	AR98S□KD-N50-◇
	Pulse Input	AR98S□K-N5-◇	AR98S□K-N7.2-◇	AR98S□K-N10-◇	AR98S□K-N25-◇	AR98S□K-N36-◇	AR98S□K-N50-◇
Max. Holding Torque	N·m	10	14	20	37		
Rotor Inertial Moment	J: kg·m <sup>2</sup>	1100×10 <sup>-7</sup> [1220×10 <sup>-7</sup> ]*1					
Gear Ratio		5	7.2	10	25	36	50
Resolution	When Set to 1000P/R	0.072°/Pulse	0.05°/Pulse	0.036°/Pulse	0.0144°/Pulse	0.01°/Pulse	0.0072°/Pulse
Permissible Torque	N·m	10	14	20	37		
Maximum Torque	N·m	28	35		56	60	
Holding Torque at Motor Standstill	While Power is Supplied N·m	5	7.2	10	25	36	37
	Electromagnetic Brake N·m	5	7.2	10	25	36	37
Permissible Speed Range	r/min	0~400	0~277	0~200	0~80	0~55	0~40
Backlash	arc minute (degrees)	2(0.034°)			3(0.05°)		
Power Supply Input	Voltage	24 VDC±10% (24 VDC±5%)*2/48 VDC±5%*3					
	Input Current	2.5(3.1)*2					
Electromagnetic Brake*4	Power Supply Input	24 VDC±5%*5 0.25 A					

● Either **A** (single shaft) or **M** (electromagnetic brake) indicating the configuration is entered where the box □ is located within the product name.

A number indicating the desired length of **1** (1 m), **2** (2 m) or **3** (3 m) for the cable included with the product is entered where the box ◇ is located within the product name.

\*1 The brackets [ ] indicate the specifications for the electromagnetic brake type.

\*2 The parentheses () indicate the specifications for the built-in controller type.

\*3 When the motor is operated from 48 VDC input, use an inertial load 10 times the rotor inertial ratio or less and twice the safety factor or more when calculating the acceleration torque.

\*4 For the pulse input type, a separate power supply for the electromagnetic brake is also required.

\*5 If the wiring distance between the motor and driver is extended to 20 m or longer using an accessory cable (sold separately), the 24 VDC±4% specification applies.

## Speed – Torque Characteristics

AR98 Gear Ratio 5

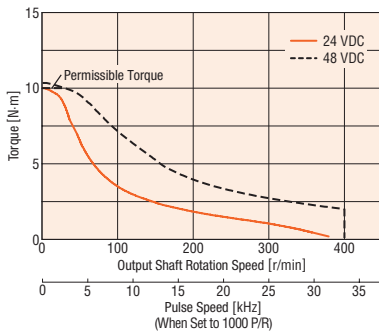

AR98 Gear Ratio 7.2

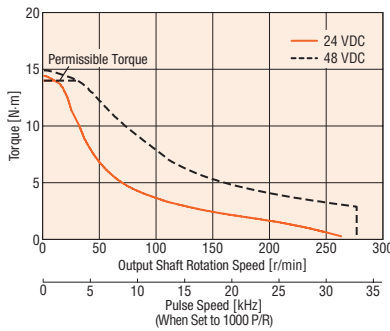

AR98 Gear Ratio 10

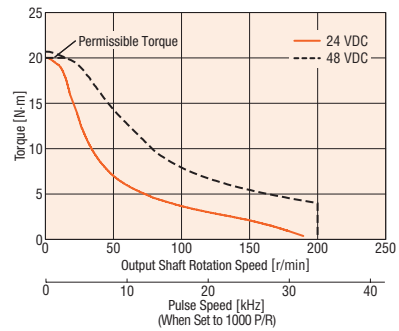

AR98 Gear Ratio 25

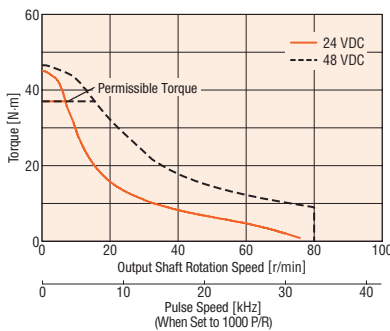

AR98 Gear Ratio 36

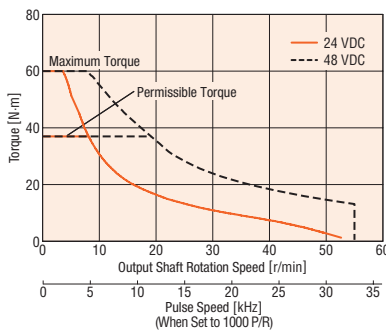

AR98 Gear Ratio 50

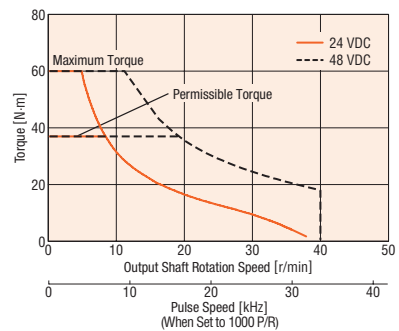

### Note

● Depending on the driving conditions, a considerable amount of heat may be generated by the motor. Be sure to keep the temperature of the motor case at approximately 100°C max.

# Harmonic Geared Type Frame Size 30 mm, 42 mm

## Specifications RoHS



Product Name	Built-in Controller Pulse Input	AR24SAKD-H50-◇	AR24SAKD-H100-◇	AR46S□KD-H50-◇	AR46S□KD-H100-◇
		AR24SAK-H50-◇	AR24SAK-H100-◇	AR46S□K-H50-◇	AR46S□K-H100-◇
Max. Holding Torque	N·m	1.8	2.4	3.5	5
Rotor Inertial Moment	J: kg·m <sup>2</sup>	14×10 <sup>-7</sup>		75×10 <sup>-7</sup> [90×10 <sup>-7</sup> ]*1	
Gear Ratio		50	100	50	100
Resolution	When Set to 1000P/R	0.0072°/Pulse	0.0036°/Pulse	0.0072°/Pulse	0.0036°/Pulse
Permissible Torque	N·m	1.8	2.4	3.5	5
Maximum Torque	N·m	3.3	4.8	8.3	11
Holding Torque at Motor Standstill	While Power is Supplied N·m Electromagnetic Brake N·m	1.3 —	2.4 —	3.5 3.5	5 5
Permissible Speed Range	r/min	0~70	0~35	0~70	0~35
Lost Motion (Load torque)	arc minute (degrees)	1.5 or less (±0.09 N·m)	1.5 or less (±0.12 N·m)	1.5 or less (±0.16 N·m)	1.5 or less (±0.2 N·m)
Power Supply Input	Voltage	24 VDC±10% (24 VDC±5%)*2		24 VDC±10% (24 VDC±5%)*2/48 VDC±5%	
	Input Current	0.9(1.3)*2		1.4(1.8)*2	
Electromagnetic Brake*3	Power Supply Input	—	—	24 VDC±5%*4 0.08 A	

- Either **A** (single shaft) or **M** (electromagnetic brake) indicating the configuration is entered where the box □ is located within the product name.  
A number indicating the desired length of **1** (1 m), **2** (2 m) or **3** (3 m) for the cable included with the product is entered where the box ◇ is located within the product name.
- \*1 The brackets [ ] indicate the specifications for the electromagnetic brake type.
- \*2 The parentheses ( ) indicate the specifications for the built-in controller type.
- \*3 For the pulse input type, a separate power supply for the electromagnetic brake is also required.
- \*4 If the wiring distance between the motor and driver is extended to 20 m or longer using an accessory cable (sold separately), the 24 VDC±4% specification applies.

## Speed – Torque Characteristics

**AR24 Gear Ratio 50**

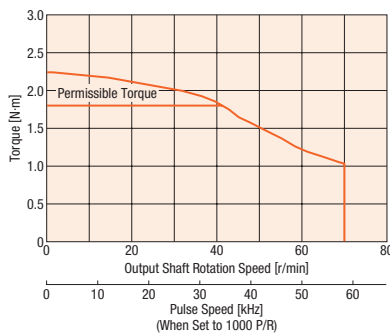

**AR24 Gear Ratio 100**

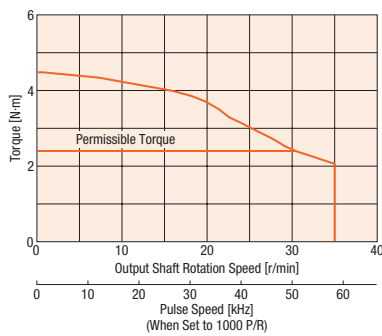

**AR46 Gear Ratio 50**

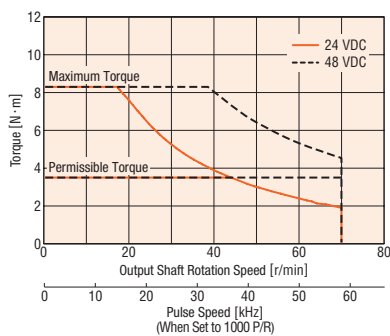

**AR46 Gear Ratio 100**

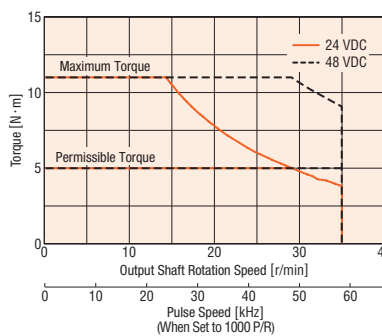

### Note

- Depending on the driving conditions, a considerable amount of heat may be generated by the motor. Be sure to keep the temperature of the motor case at approximately 100°C max.
- In order to prevent deterioration of the gear grease in the harmonic geared type, keep the temperature of the gear case at 70°C max.

Features

Lineup

System Configuration

Product Line

Specifications and Characteristics

Dimension

Connection and Operation

Combination List

Extended Functions

How to Read Specifications and Characteristics

Accessory

Controller

# Harmonic Geared Type Frame Size 60 mm, 90 mm

## Specifications RoHS



Product Name	Built-in Controller	AR66S□KD-H50-◇	AR66S□KD-H100-◇	AR98S□KD-H50-◇	AR98S□KD-H100-◇
	Pulse Input	AR66S□K-H50-◇	AR66S□K-H100-◇	AR98S□K-H50-◇	AR98S□K-H100-◇
Max. Holding Torque	N·m	5.5	8	25	37
Rotor Inertial Moment	J: kg·m <sup>2</sup>	415×10 <sup>-7</sup> [535×10 <sup>-7</sup> ]*1		1300×10 <sup>-7</sup> [1420×10 <sup>-7</sup> ]*1	
Gear Ratio		50	100	50	100
Resolution	When Set to 1000P/R	0.0072°/Pulse	0.0036°/Pulse	0.0072°/Pulse	0.0036°/Pulse
Permissible Torque	N·m	5.5	8	25	37
Maximum Torque	N·m	18	28	35	55
Holding Torque at Motor Standstill	While Power is Supplied N·m Electromagnetic Brake N·m	5.5 5.5	8 8	25 25	37 37
Permissible Speed Range	r/min	0~60	0~30	0~40	0~20
Lost Motion (Load torque)	arc minute (degrees)	0.7 or less (±0.28 N·m)		1.5 or less (±1.2 N·m)	
Power Supply Input	Voltage	24 VDC±10% (24 VDC±5%)*2/48 VDC±5%*3			
	Input Current	3.1(3.8)*2		2.5(3.1)*2	
Electromagnetic Brake*4	Power Supply Input	24 VDC±5%*5 0.25 A			

● Either **A** (single shaft) or **M** (electromagnetic brake) indicating the configuration is entered where the box □ is located within the product name.

A number indicating the desired length of **1** (1 m), **2** (2 m) or **3** (3 m) for the cable included with the product is entered where the box ◇ is located within the product name.

\*1 The brackets [ ] indicate the specifications for the electromagnetic brake type.

\*2 The parentheses () indicate the specifications for the built-in controller type.

\*3 When the motor is operated from 48 VDC input, use an inertial load 10 times the rotor inertial ratio or less and twice the safety factor or more when calculating the acceleration torque.

\*4 For the pulse input type, a separate power supply for the electromagnetic brake is also required.

\*5 If the wiring distance between the motor and driver is extended to 20 m or longer using an accessory cable (sold separately), the 24 VDC±4% specification applies.

## Speed – Torque Characteristics

**AR66 Gear Ratio 50**

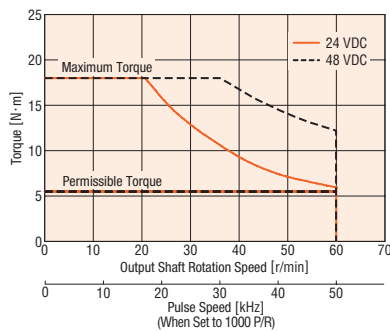

**AR66 Gear Ratio 100**

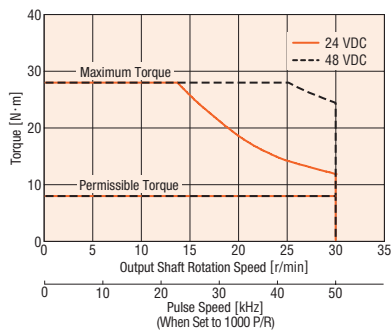

**AR98 Gear Ratio 50**

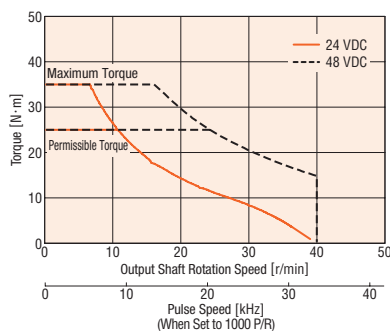

**AR98 Gear Ratio 100**

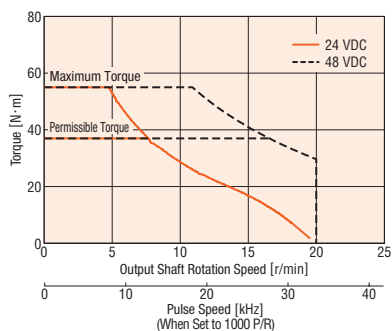

### Note

● Depending on the driving conditions, a considerable amount of heat may be generated by the motor. Be sure to keep the temperature of the motor case at approximately 100°C max.

● In order to prevent deterioration of the gear grease in the harmonic geared type, keep the temperature of the gear case at 70°C max.

## Driver Specifications

		Built-in Controller Type	Pulse Input Type
Max. Input Pulse Frequency		—	When the programmable controller is generating line driver output: 500 kHz (Duty: 50%) When the programmable controller is generating open-collector output: 250kHz (Duty: 50%)*
Positioning Data		64 Points	—
Positioning Operation	Independent	○	—
	Linked	○	—
	Linked 2	○	—
	Sequential	○	—
	Direct	○	—
	Pushing	○	○
Continuous Operation		○	—
JOG Operation		○	—
Return-To-Home Operation		○	—
Test Operation		○	○
Absolute Backup System		○	—
Control Module <b>OPX-2A</b>		○	○
Data Setting Software <b>MEXE02</b>		○	○

\* A value when the general-purpose cable (**CC36D1-1**) sold separately was used. General purpose cable → Page 58

## Built-in Controller Type RS-485 Communication Specifications

Protocol	Modbus protocol (Modbus RTU mode)
Electrical Characteristics	EIA-485 conformance Use a twisted-pair cable (TIA/EIA-568B CAT5e or better recommended). The total extension length must be 50 m or less.
Transmission Method	Half duplex
Baud Rate	9600 bps/19200 bps/38400 bps/57600 bps/115200 bps
Physical Layer	Start-stop synchronization (data length: 8 bits, stop bits: 1 or 2 bits, parity: none, even, or odd)
Connection Type	Up to 31 drivers can be connected to a single programmable controller (master equipment).

## General Specifications

		Motor	Driver	
			Built-in Controller Type	Pulse Input Type
Heat Resistance Class		130 (B)	—	
Insulation Resistance		100 MΩ min. when measured with a 500 VDC megger between the following locations: • Case - Motor and Sensor Windings • Case - Electromagnetic Brake Windings	100 MΩ min. when measured with a 500 VDC megger between the following locations: • FG terminal - Power input terminal	—
Dielectric Strength		No abnormality is judged with the following application for 1 minute: • Case - Motor and Sensor Windings 1.0 kV at 50 Hz or 60 Hz • Case - Electromagnetic Brake Windings 1.0 kV at 50 Hz or 60 Hz	No abnormality is judged with the following application for 1 minute: • FG terminal - Power input terminal 500 VAC at 50 Hz or 60 Hz	—
Operating Environment (In operation)	Ambient Temperature	−10~+50°C (non-freezing)*1: Standard Type, <b>TH</b> , <b>PS</b> and <b>PN</b> Geared Types 0~+40°C (non-freezing)*1: Harmonic Geared Type	0~+50°C (non-freezing)	
	Ambient Humidity	85% max. (non-condensing)		
	Atmosphere	Use in an area without corrosive gases and dust. The product should not be exposed to water, oil or other liquids.		
Degree of Protection		IP20	IP10	IP20
Stop Position Accuracy		<b>AR24, AR26, AR46</b> : ±4 minutes (±0.067°) <b>AR66, AR69, AR98</b> : ±3 minutes (±0.05°)		
Shaft Runout		0.05 T. I. R. (mm)*2	—	
Concentricity of Installing Pilot to the Shaft		0.075 T. I. R. (mm)*2	—	
Perpendicularity of Installation Surface to the Shaft		0.075 T. I. R. (mm)*2	—	

\*1 When a heat sink of a capacity at least equivalent to an aluminum plate with a size of 100×100 mm, 6 mm thick is installed

\*2 T. I. R. (Total Indicator Reading): The total dial gauge reading when the measurement section is rotated one revolution centered on the reference axis center.

### Note

● Do not perform the insulation resistance test or dielectric voltage withstand test while the motor and driver are connected.

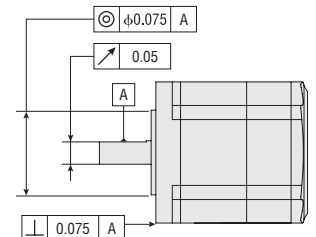

## Load Torque – Driver Input Current Characteristics

This is the relationship between the load torque and driver input current at each speed when the motor is actually operated. From these characteristics, the power supply capacity required for use in multi-axis operation can be estimated. For the geared type, convert to torque and speed at the motor shaft.

### 24 VDC

#### AR24

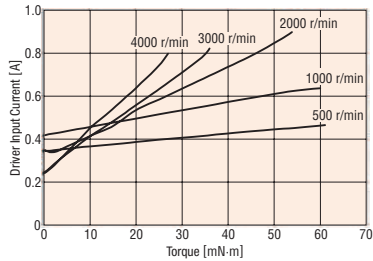

#### AR26

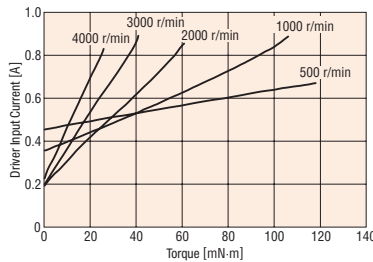

#### AR46

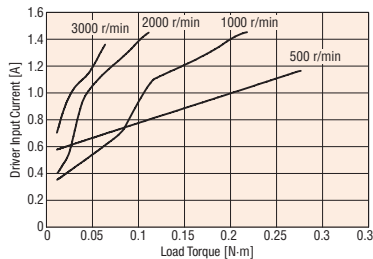

#### AR66

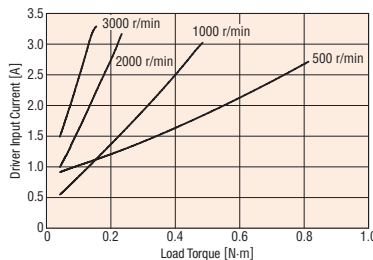

#### AR69

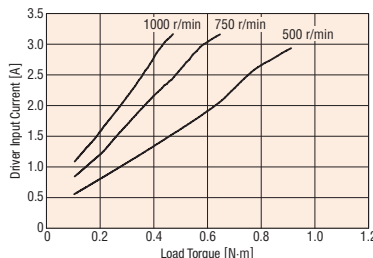

#### AR98

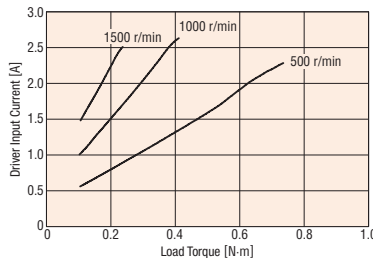

Motor shaft speed = Gear output shaft speed × Gear ratio [r/min]

$$\text{Motor shaft torque} = \frac{\text{Gear output shaft torque}}{\text{Gear ratio}} \text{ [N·m]}$$

### 48 VDC

#### AR46

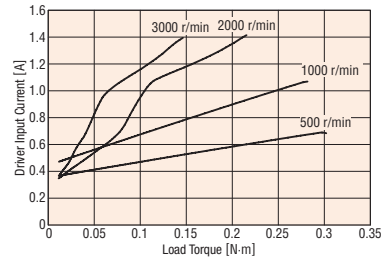

#### AR66

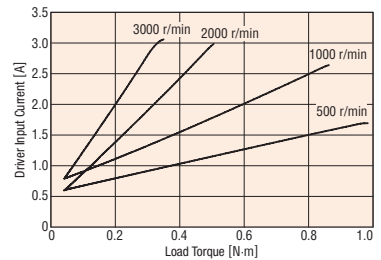

#### AR69

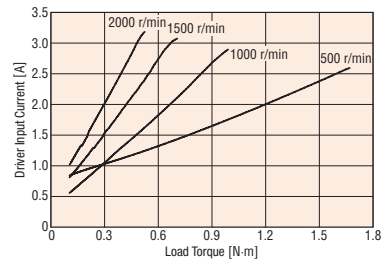

#### AR98

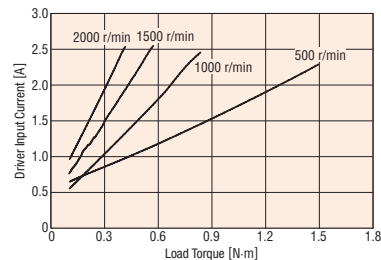

# Permissible Overhung Load and Permissible Thrust Load

Unit = N

Type	Motor Frame Size	Type	Gear Ratio	Permissible Overhung Load					Permissible Thrust Load
				Distance from Shaft End mm					
				0	5	10	15	20	
Standard Type	28 mm	<b>AR24</b>	—	25	34	52	—	—	1.5
		<b>AR26</b>	—						2.2
	42 mm	<b>AR46</b>	—	35	44	58	85	—	4.6[6.1]*
	60 mm	<b>AR66</b>		90	100	130	180	270	8.8[11.8]*
		<b>AR69</b>		13.7[16.7]*					
85 mm	<b>AR98</b>	260	290	340	390	480	18[24]*		
TH Geared Type	28 mm	<b>AR24</b>	<b>7.2, 10, 20, 30</b>	15	17	20	23	—	10
	42 mm	<b>AR46</b>	<b>3.6, 7.2, 10, 20, 30</b>	10	14	20	30	—	15
	60 mm	<b>AR66</b>		70	80	100	120	150	40
	90 mm	<b>AR98</b>		220	250	300	350	400	100
PS Geared Type	28 mm	<b>AR24</b>	<b>5, 7.2, 10</b>	45	60	80	100	—	20
				73	84	100	123	—	50
	42 mm	<b>AR46</b>	<b>25, 36, 50</b>	109	127	150	184	—	100
				200	220	250	280	320	
				250	270	300	340	390	
	60 mm	<b>AR66</b>	<b>5, 7.2, 10</b>	330	360	400	450	520	300
				480	540	600	680	790	
				850	940	1050	1190	1380	
				930	1030	1150	1310	1520	
	90 mm	<b>AR98</b>	<b>5, 7.2, 10</b>	1050	1160	1300	1480	1710	300
25				850	940	1050	1190	1380	
36				930	1030	1150	1310	1520	
50				1050	1160	1300	1480	1710	
PN Geared Type	28 mm	<b>AR24</b>	<b>5, 7.2, 10</b>	45	60	80	100	—	20
				100	120	150	190	—	100
	60 mm	<b>AR66</b>	<b>5, 7.2, 10</b>	200	220	250	280	320	
				250	270	300	340	390	
				330	360	400	450	520	
	90 mm	<b>AR98</b>	<b>5, 7.2, 10</b>	480	520	550	580	620	300
				480	540	600	680	790	
				850	940	1050	1110	1190	
				930	1030	1150	1220	1300	
				1050	1160	1300	1380	1490	
Harmonic Geared Type	30 mm	<b>AR24</b>	<b>50, 100</b>	100	135	175	250	—	140
	42 mm	<b>AR46</b>		180	220	270	360	510	220
	60 mm	<b>AR66</b>		320	370	440	550	720	450
	90 mm	<b>AR98</b>		1090	1150	1230	1310	1410	1300

\*The brackets [ ] indicate the value for the electromagnetic brake type.

**Note**

● With a double shaft product, the output shaft located on the opposite side of the motor output shaft is used to install a slit disk or similar device. Do not apply any load torque, overhung load or thrust load on this output shaft.

Features

Lineup

System Configuration

Product Line

Specifications and Characteristics

Dimension

Connection and Operation

Combination List

Extended Functions

How to Read Specifications and Characteristics

Accessory

Controller

## Dimensions (Unit = mm)

### ● Motor

### ◇ Standard Type

### Frame Size 28 mm

Product Name		Motor Product Name	L1	L2	Mass kg	CAD
Built-in Controller	Pulse Input					
<b>AR24SAKD</b> -◇	<b>AR24SAK</b> -◇	ARM24SAK	45	-	0.15	B705
<b>AR24SBKD</b> -◇	<b>AR24SBK</b> -◇	ARM24SBK		56		
<b>AR26SAKD</b> -◇	<b>AR26SAK</b> -◇	ARM26SAK	65	-	0.22	B706
<b>AR26SBKD</b> -◇	<b>AR26SBK</b> -◇	ARM26SBK		76		

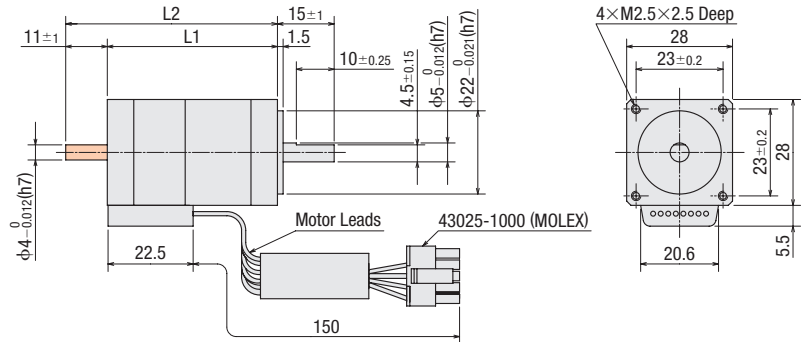

### Frame Size 42 mm

Product Name		Motor Product Name	Mass kg	CAD
Built-in Controller	Pulse Input			
<b>AR46SAKD</b> -◇	<b>AR46SAK</b> -◇	ARM46SAK	0.44	B718
<b>AR46SBKD</b> -◇	<b>AR46SBK</b> -◇	ARM46SBK		

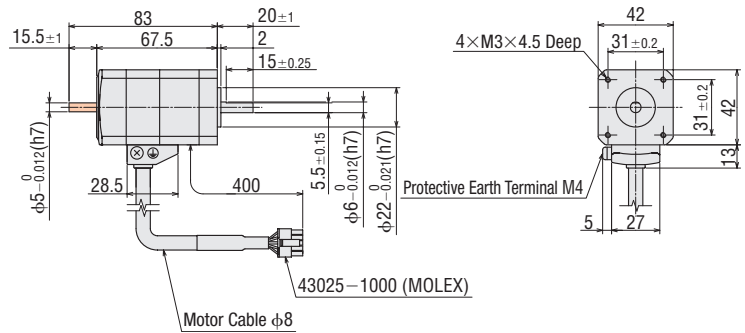

### Frame Size 60 mm

Product Name		Motor Product Name	L1	L2	Mass kg	CAD
Built-in Controller	Pulse Input					
<b>AR66SAKD</b> -◇	<b>AR66SAK</b> -◇	ARM66SAK	64	-	0.87	B719
<b>AR66SBKD</b> -◇	<b>AR66SBK</b> -◇	ARM66SBK		85.5		
<b>AR69SAKD</b> -◇	<b>AR69SAK</b> -◇	ARM69SAK	89.5	-	1.37	B720
<b>AR69SBKD</b> -◇	<b>AR69SBK</b> -◇	ARM69SBK		111		

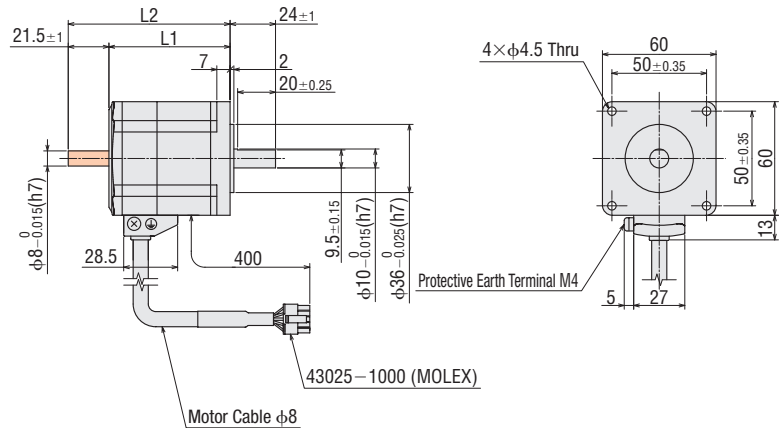

● A number indicating the desired length of **1** (1 m), **2** (2 m) or **3** (3 m) for the cable included with the product is entered where the box ◇ is located within the product name.

● These dimensions are for double shaft models. For single shaft models, ignore the shaded areas.

### Frame Size 85 mm

Product Name		Motor Product Name	Mass kg	CAD
Built-in Controller	Pulse Input			
<b>AR98SAKD</b> -◇	<b>AR98SAK</b> -◇	ARM98SAK	1.85	B721
<b>AR98SBKD</b> -◇	<b>AR98SBK</b> -◇	ARM98SBK		

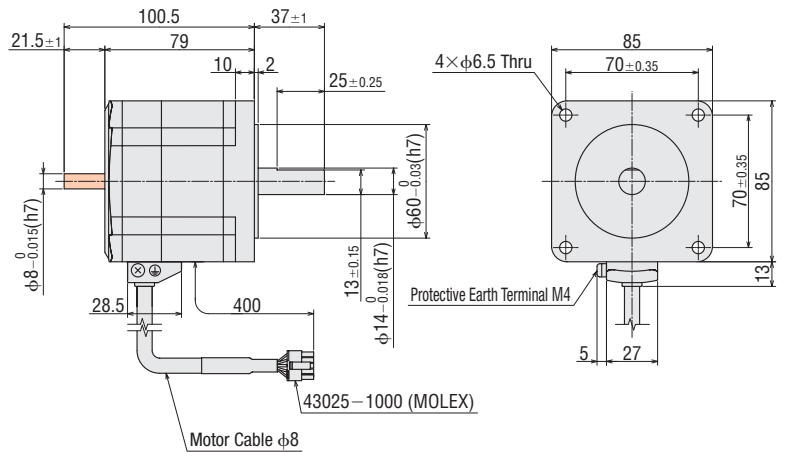

### ◇ Standard Type with Electromagnetic Brake

#### Frame Size 42 mm

Product Name		Motor Product Name	Mass kg	CAD
Built-in Controller	Pulse Input			
<b>AR46SMKD</b> -◇	<b>AR46SMK</b> -◇	ARM46SMK	0.57	B722

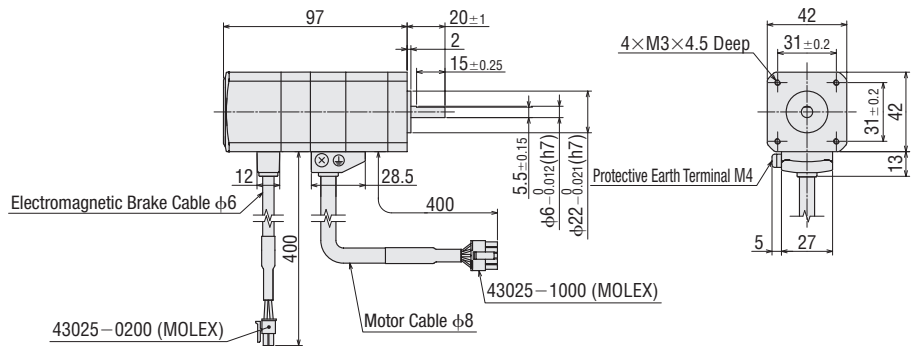

#### Frame Size 60 mm

Product Name		Motor Product Name	L	Mass kg	CAD
Built-in Controller	Pulse Input				
<b>AR66SMKD</b> -◇	<b>AR66SMK</b> -◇	ARM66SMK	99	1.13	B723
<b>AR69SMKD</b> -◇	<b>AR69SMK</b> -◇	ARM69SMK	124.5	1.63	B724

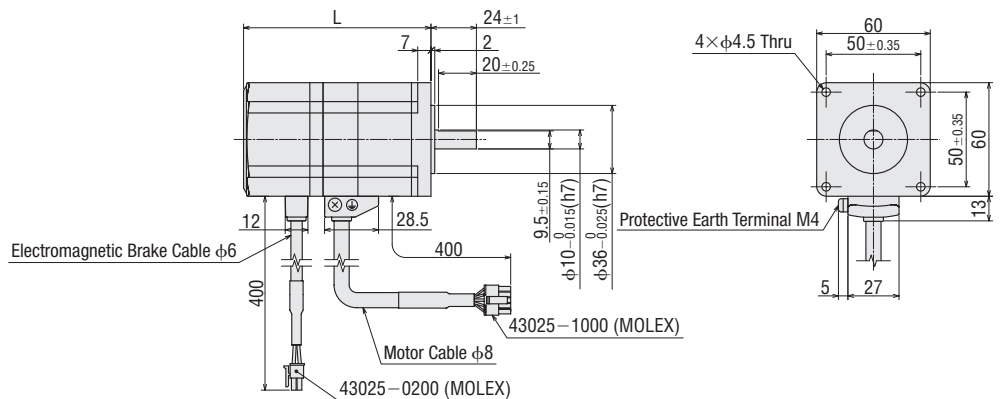

● A number indicating the desired length of **1** (1 m), **2** (2 m) or **3** (3 m) for the cable included with the product is entered where the box ◇ is located within the product name.

● The dimensions of the standard type frame size 85 mm are for double shaft models. For single shaft models, ignore the shaded areas.

Features

Lineup

System Configuration

Product Line

Specifications and Characteristics

Dimension

Connection and Operation

Combination List

Extended Functions

How to Read Specifications and Characteristics

Accessory

Controller

### Frame Size 85 mm

Product Name		Motor Product Name	Mass kg	CAD
Built-in Controller	Pulse Input			
<b>AR98SMKD</b> -◇	<b>AR98SMK</b> -◇	ARM98SMK	2.3	B725

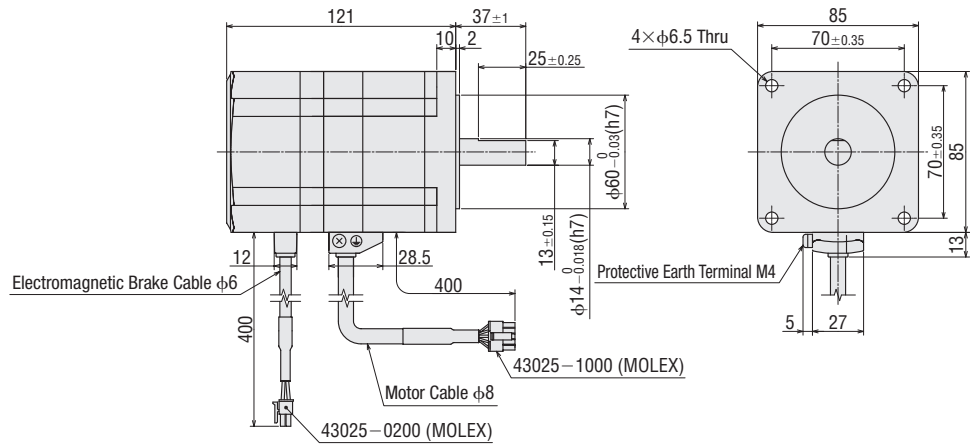

### ◇ TH Geared Type Frame Size 28 mm

Product Name		Motor Product Name	Gear Ratio	Mass kg	CAD
Built-in Controller	Pulse Input				
<b>AR24SAKD-T</b> -◇	<b>AR24SAK-T</b> -◇	ARM24SAK-T	<b>7.2, 10, 20, 30</b>	0.21	B707

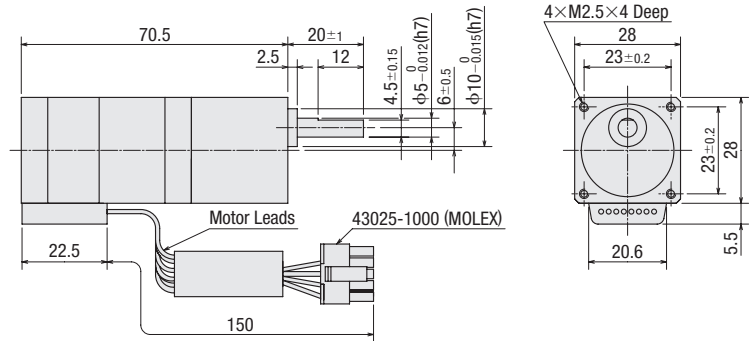

### Frame Size 42 mm

Product Name		Motor Product Name	Gear Ratio	Mass kg	CAD
Built-in Controller	Pulse Input				
<b>AR46SAKD-T</b> -◇	<b>AR46SAK-T</b> -◇	ARM46SAK-T	<b>3.6, 7.2, 10, 20, 30</b>	0.59	B726

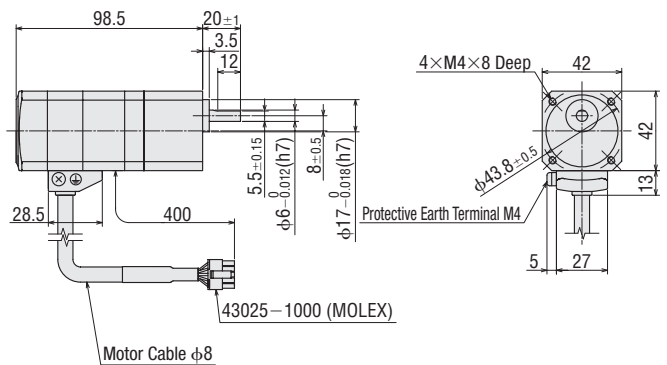

● A number indicating the gear ratio is entered where the box ■ is located within the product name.

● A number indicating the desired length of 1 (1 m), 2 (2 m) or 3 (3 m) for the cable included with the product is entered where the box ◇ is located within the product name.

### Frame Size 60 mm

Product Name		Motor Product Name	Gear Ratio	Mass kg	CAD
Built-in Controller	Pulse Input				
<b>AR66SAKD-T</b> ◊	<b>AR66SAK-T</b> ◊	ARM66SAK-T	<b>3.6, 7.2, 10, 20, 30</b>	1.27	B727

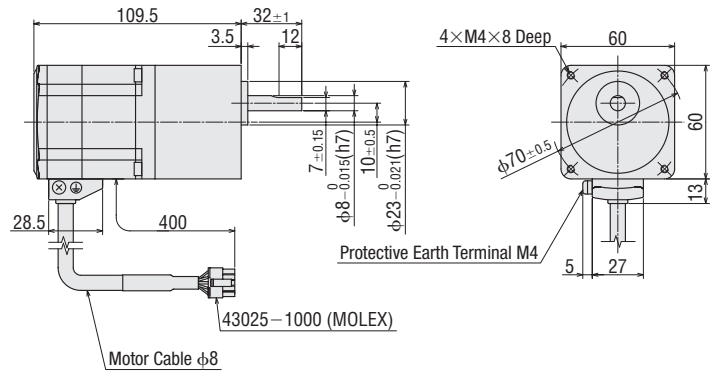

### Frame Size 90 mm

Product Name		Motor Product Name	Gear Ratio	Mass kg	CAD
Built-in Controller	Pulse Input				
<b>AR98SAKD-T</b> ◊	<b>AR98SAK-T</b> ◊	ARM98SAK-T	<b>3.6, 7.2, 10, 20, 30</b>	3	B728

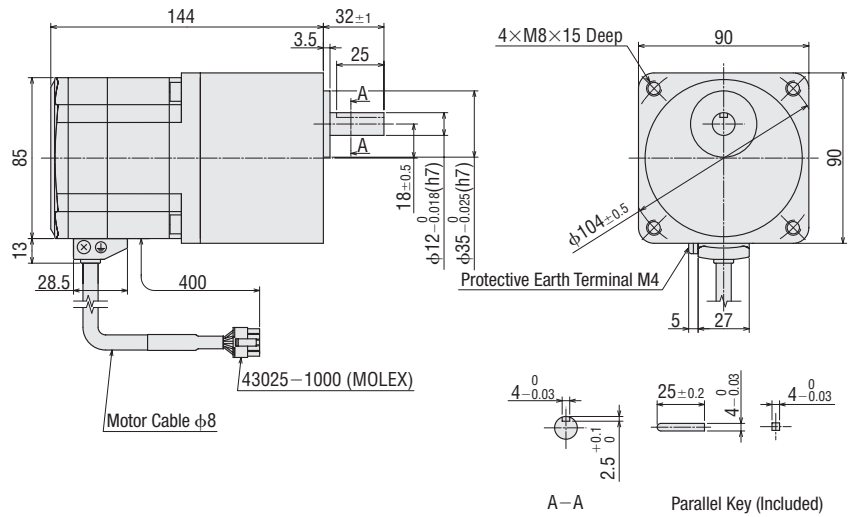

### ◇ TH Geared Type with Electromagnetic Brake

#### Frame Size 42 mm

Product Name		Motor Product Name	Gear Ratio	Mass kg	CAD
Built-in Controller	Pulse Input				
<b>AR46SMKD-T</b> ◊	<b>AR46SMK-T</b> ◊	ARM46SMK-T	<b>3.6, 7.2, 10, 20, 30</b>	0.72	B729

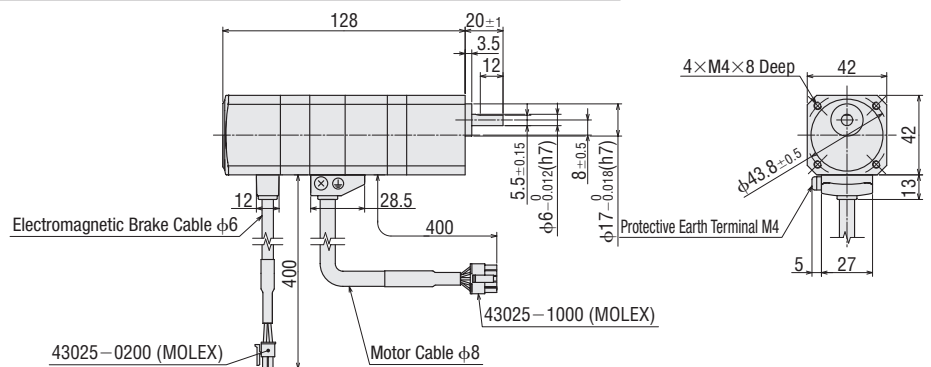

● A number indicating the gear ratio is entered where the box ■ is located within the product name.

● A number indicating the desired length of **1** (1 m), **2** (2 m) or **3** (3 m) for the cable included with the product is entered where the box ◊ is located within the product name.

Features

Lineup

System Configuration

Product Line

Specifications and Characteristics

Dimension

Connection and Operation

Combination List

Extended Functions

How to Read Specifications and Characteristics

Accessory

Controller

### Frame Size 60 mm

Product Name		Motor Product Name	Gear Ratio	Mass kg	CAD
Built-in Controller	Pulse Input				
<b>AR66SMKD-T</b> ■-◇	<b>AR66SMK-T</b> ■-◇	ARM66SMK-T■	<b>3.6, 7.2, 10, 20, 30</b>	1.53	B730

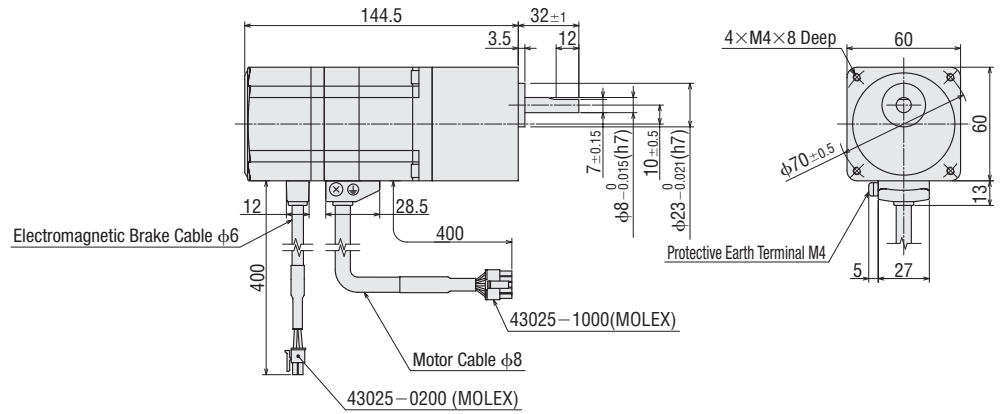

### Frame Size 90 mm

Product Name		Motor Product Name	Gear Ratio	Mass kg	CAD
Built-in Controller	Pulse Input				
<b>AR98SMKD-T</b> ■-◇	<b>AR98SMK-T</b> ■-◇	ARM98SMK-T■	<b>3.6, 7.2, 10, 20, 30</b>	3.5	B731

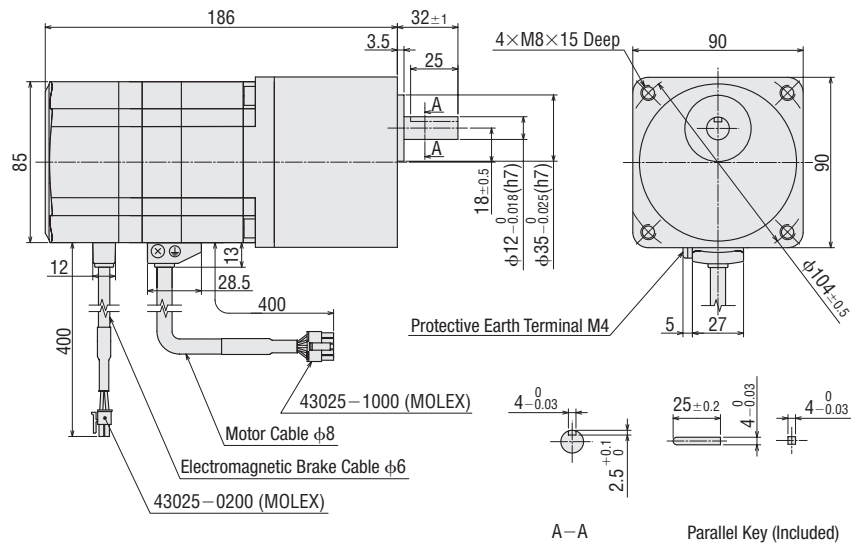

### ◇ PS Geared Type

#### Frame Size 28 mm

Product Name		Motor Product Name	Gear Ratio	Mass kg	CAD
Built-in Controller	Pulse Input				
<b>AR24SAKD-PS</b> ■-◇	<b>AR24SAK-PS</b> ■-◇	ARM24SAK-PS■	<b>5, 7.2, 10</b>	0.25	B708

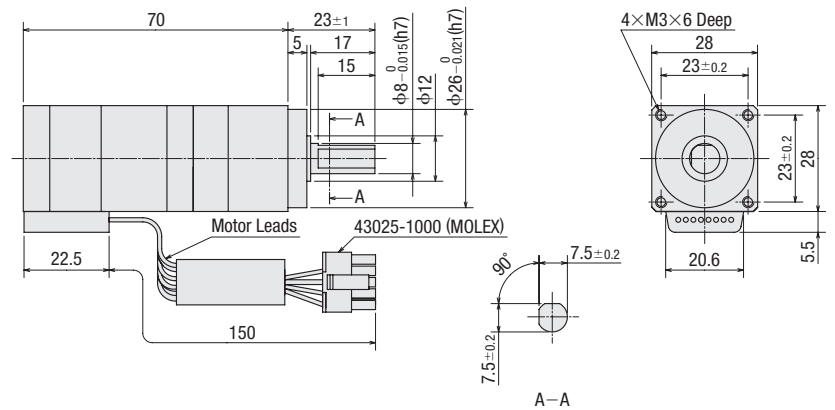

● A number indicating the gear ratio is entered where the box ■ is located within the product name.

● A number indicating the desired length of 1 (1 m), 2 (2 m) or 3 (3 m) for the cable included with the product is entered where the box ◇ is located within the product name.

### Frame Size 42 mm

Product Name		Motor Product Name	Gear Ratio	L	Mass kg	CAD
Built-in Controller	Pulse Input					
<b>AR46SAKD-PS</b> ■-◇	<b>AR46SAK-PS</b> ■-◇	ARM46SAK-PS■	<b>5, 7.2, 10</b>	95.5	0.64	B742
			<b>25, 36, 50</b>	119	0.79	B743

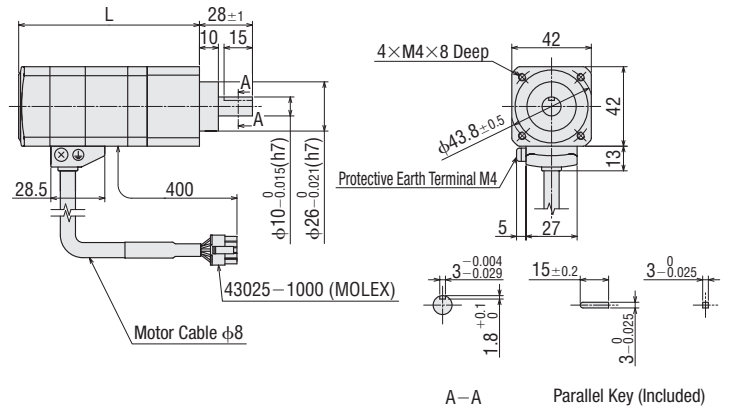

### Frame Size 60 mm

Product Name		Motor Product Name	Gear Ratio	L	Mass kg	CAD
Built-in Controller	Pulse Input					
<b>AR66SAKD-PS</b> ■-◇	<b>AR66SAK-PS</b> ■-◇	ARM66SAK-PS■	<b>5, 7.2, 10</b>	96.5	1.27	B744
			<b>25, 36, 50</b>	116.5	1.57	B745

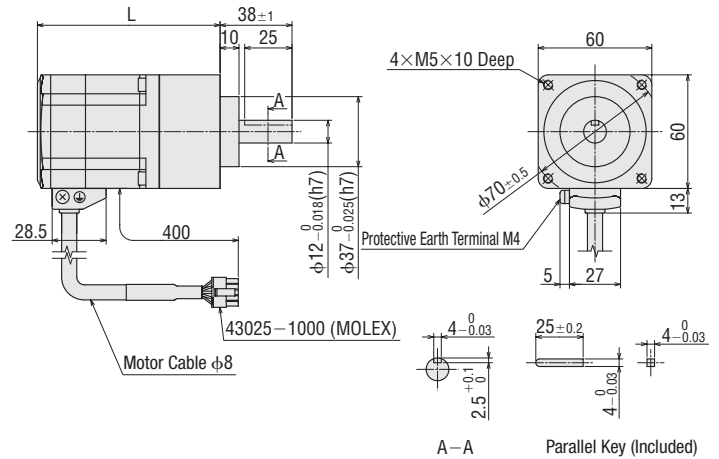

### Frame Size 90 mm

Product Name		Motor Product Name	Gear Ratio	L	Mass kg	CAD
Built-in Controller	Pulse Input					
<b>AR98SAKD-PS</b> ■-◇	<b>AR98SAK-PS</b> ■-◇	ARM98SAK-PS■	<b>5, 7.2, 10</b>	126.5	3.2	B746
			<b>25, 36, 50</b>	154	4	B747

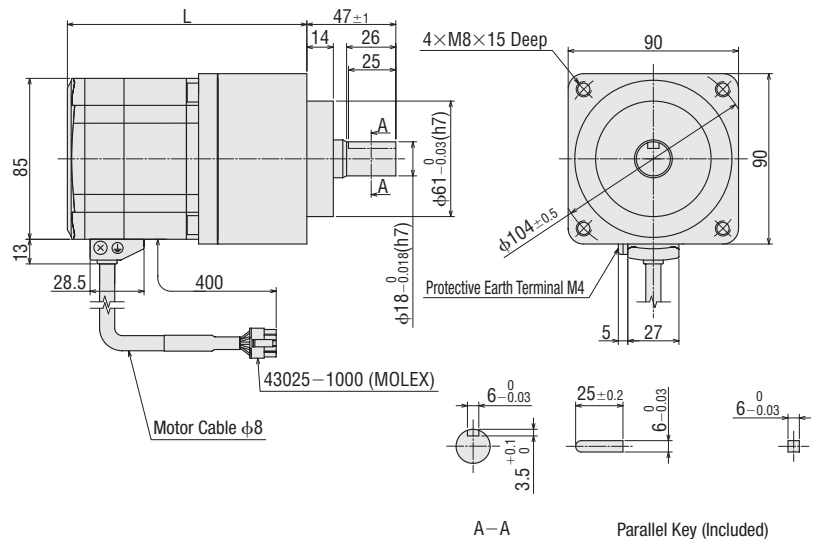

● A number indicating the gear ratio is entered where the box ■ is located within the product name.

● A number indicating the desired length of **1** (1 m), **2** (2 m) or **3** (3 m) for the cable included with the product is entered where the box ◇ is located within the product name.

Features

Lineup

System Configuration

Product Line

Specifications and Characteristics

Dimension

Connection and Operation

Combination List

Extended Functions

How to Read Specifications and Characteristics

Accessory

Controller

◆ PS Geared Type with Electromagnetic Brake

Frame Size 42 mm

Product Name		Motor Product Name	Gear Ratio	L	Mass kg	CAD
Built-in Controller	Pulse Input					
<b>AR46SMKD-PS</b> ■-◇	<b>AR46SMK-PS</b> ■-◇	ARM46SMK-PS■	<b>5, 7.2, 10</b>	125	0.77	B748
			<b>25, 36, 50</b>	148.5	0.92	B749

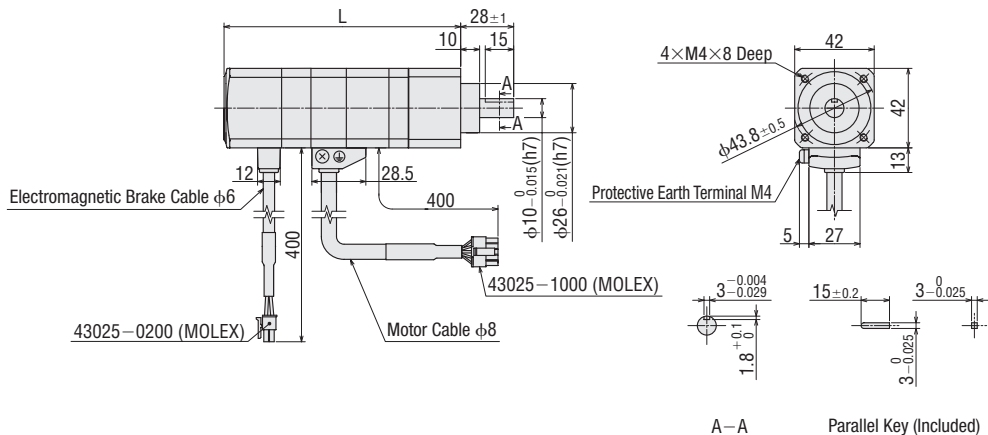

Frame Size 60 mm

Product Name		Motor Product Name	Gear Ratio	L	Mass kg	CAD
Built-in Controller	Pulse Input					
<b>AR66SMKD-PS</b> ■-◇	<b>AR66SMK-PS</b> ■-◇	ARM66SMK-PS■	<b>5, 7.2, 10</b>	131.5	1.53	B750
			<b>25, 36, 50</b>	151.5	1.83	B751

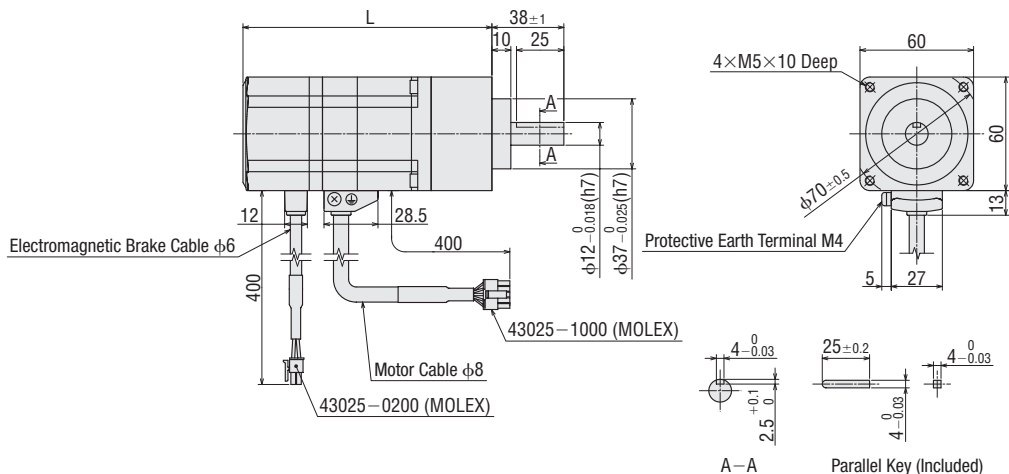

Frame Size 90 mm

Product Name		Motor Product Name	Gear Ratio	L	Mass kg	CAD
Built-in Controller	Pulse Input					
<b>AR98SMKD-PS</b> ■-◇	<b>AR98SMK-PS</b> ■-◇	ARM98SMK-PS■	<b>5, 7.2, 10</b>	168.5	3.7	B752
			<b>25, 36, 50</b>	196	4.5	B753

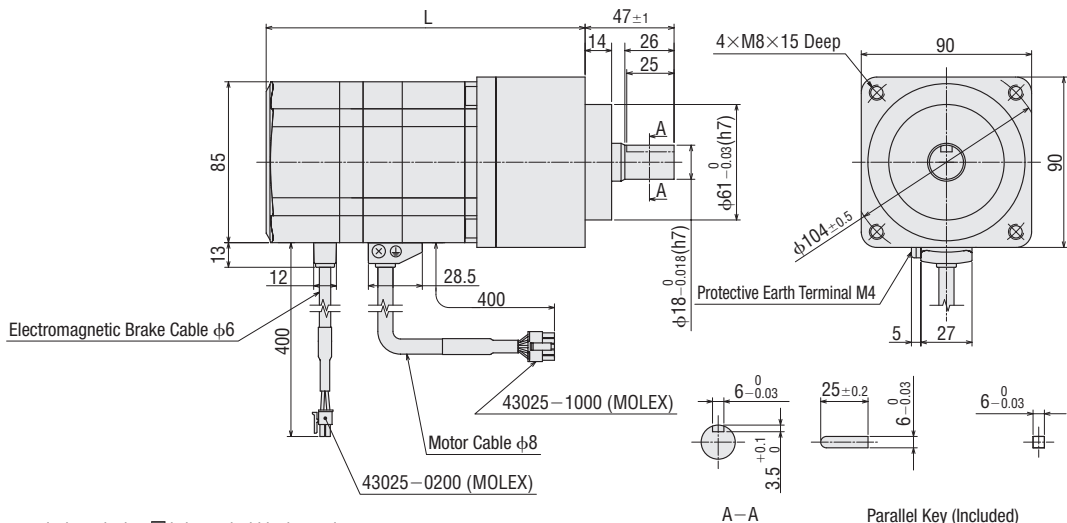

- A number indicating the gear ratio is entered where the box ■ is located within the product name.
- A number indicating the desired length of 1 (1 m), 2 (2 m) or 3 (3 m) for the cable included with the product is entered where the box ◇ is located within the product name.

◇ PN Geared Type

Frame Size 28 mm

Product Name		Motor Product Name	Gear Ratio	Mass kg	CAD
Built-in Controller	Pulse Input				
<b>AR24SAKD-N</b> ■-◇	<b>AR24SAK-N</b> ■-◇	ARM24SAK-N■	<b>5, 7.2, 10</b>	0.28	B709

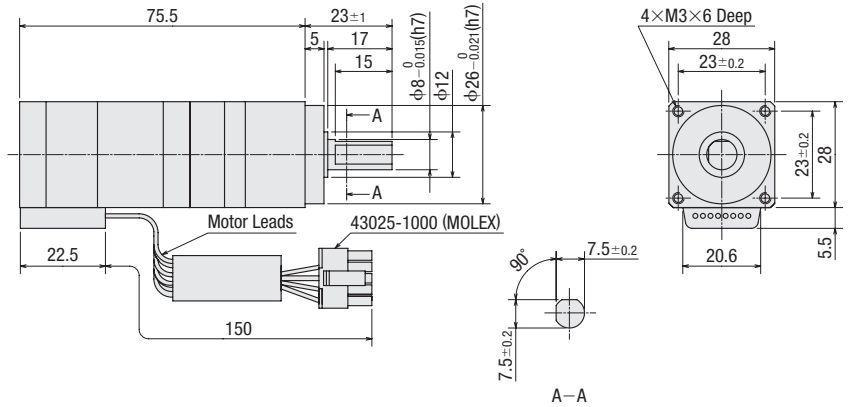

Frame Size 42 mm

Product Name		Motor Product Name	Gear Ratio	Mass kg	CAD
Built-in Controller	Pulse Input				
<b>AR46SAKD-N</b> ■-◇	<b>AR46SAK-N</b> ■-◇	ARM46SAK-N■	<b>5, 7.2, 10</b>	0.7	B732

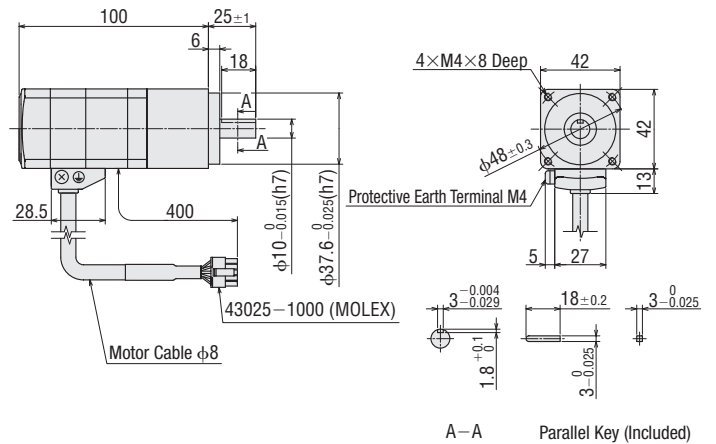

Frame Size 60 mm

Product Name		Motor Product Name	Gear Ratio	L	Mass kg	CAD
Built-in Controller	Pulse Input					
<b>AR66SAKD-N</b> ■-◇	<b>AR66SAK-N</b> ■-◇	ARM66SAK-N■	<b>5, 7.2, 10</b>	108.5	1.47	B733
			<b>25, 36, 50</b>	124.5	1.7	B734

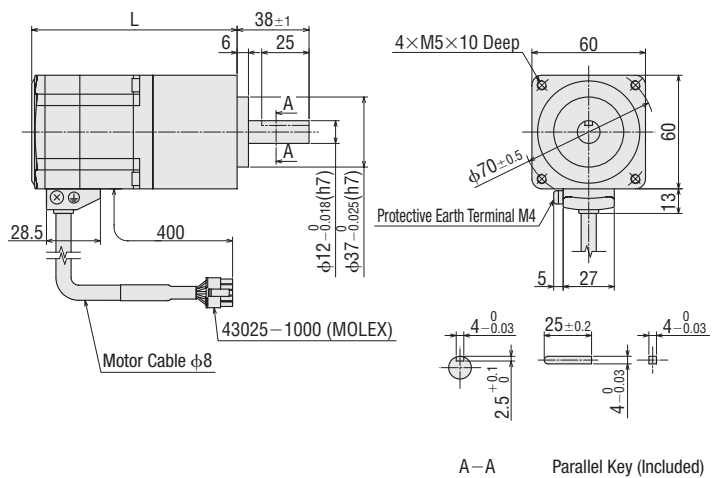

● A number indicating the gear ratio is entered where the box ■ is located within the product name.

● A number indicating the desired length of 1 (1 m), 2 (2 m) or 3 (3 m) for the cable included with the product is entered where the box ◇ is located within the product name.

Features

Lineup

System Configuration

Product Line

Specifications and Characteristics

Dimension

Connection and Operation

Combination List

Extended Functions

How to Read Specifications and Characteristics

Accessory

Controller

### Frame Size 90 mm

Product Name		Motor Product Name	Gear Ratio	L	Mass kg	CAD
Built-in Controller	Pulse Input					
<b>AR98SAKD-N</b> ■-◇	<b>AR98SAK-N</b> ■-◇	ARM98SAK-N■	<b>5, 7.2, 10</b>	139.5	3.7	B735
			<b>25, 36, 50</b>	162.5	4.4	B736

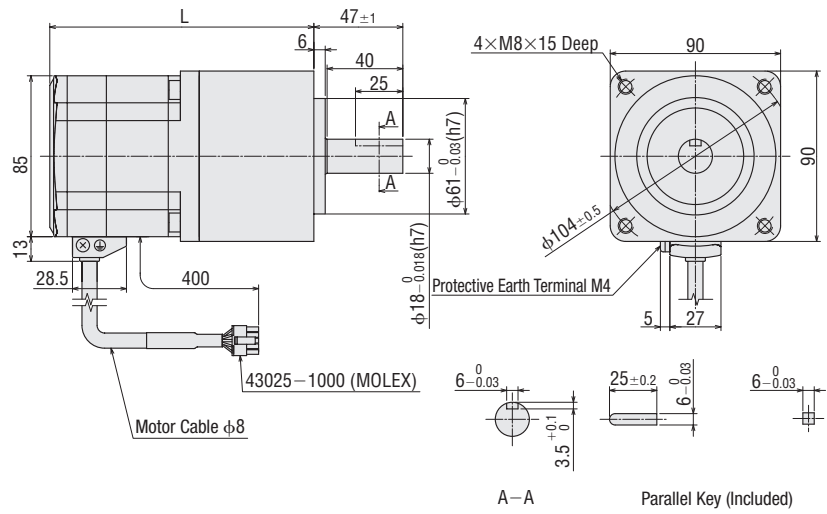

### ◇ PN Geared Type with Electromagnetic Brake

#### Frame Size 42 mm

Product Name		Motor Product Name	Gear Ratio	Mass kg	CAD
Built-in Controller	Pulse Input				
<b>AR46SMKD-N</b> ■-◇	<b>AR46SMK-N</b> ■-◇	ARM46SMK-N■	<b>5, 7.2, 10</b>	0.83	B737

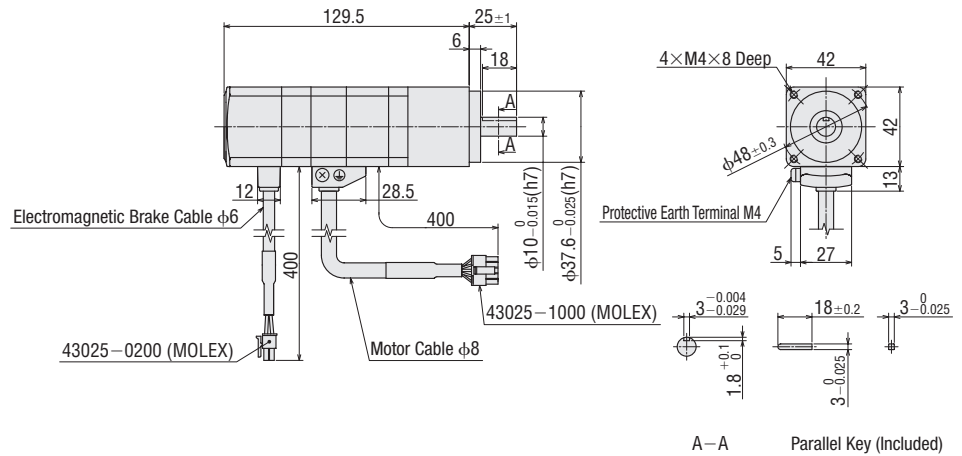

### Frame Size 60 mm

Product Name		Motor Product Name	Gear Ratio	L	Mass kg	CAD
Built-in Controller	Pulse Input					
<b>AR66SMKD-N</b> ■-◇	<b>AR66SMK-N</b> ■-◇	ARM66SMK-N■	<b>5, 7.2, 10</b>	143.5	1.73	B738
			<b>25, 36, 50</b>	159.5	1.96	B739

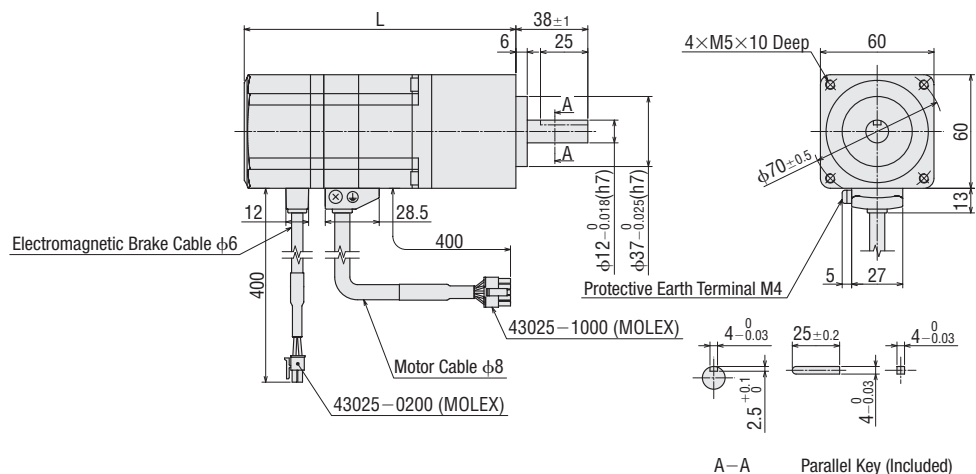

● A number indicating the gear ratio is entered where the box ■ is located within the product name.

● A number indicating the desired length of 1 (1 m), 2 (2 m) or 3 (3 m) for the cable included with the product is entered where the box ◇ is located within the product name.

### Frame Size 90 mm

Product Name		Motor Product Name	Gear Ratio	L	Mass kg	CAD
Built-in Controller	Pulse Input					
AR98SMKD-N $\blacksquare$ -◇	AR98SMK-N $\blacksquare$ -◇	ARM98SMK-N $\blacksquare$	5, 7.2, 10	181.5	4.2	B740
			25, 36, 50	204.5	4.9	B741

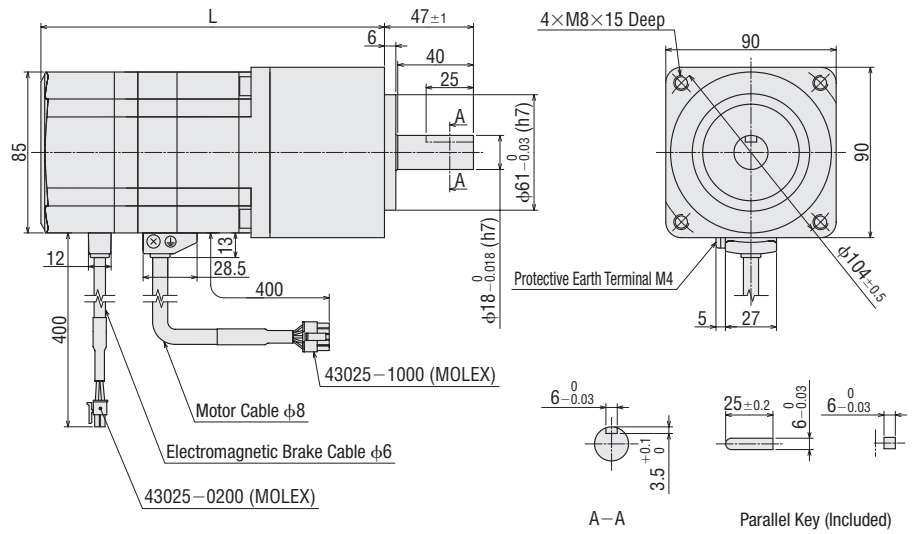

### ◇ Harmonic Geared Type

### Frame Size 30 mm

Product Name		Motor Product Name	Gear Ratio	Mass kg	CAD
Built-in Controller	Pulse Input				
AR24SAKD-H $\blacksquare$ -◇	AR24SAK-H $\blacksquare$ -◇	ARM24SAK-H $\blacksquare$	50, 100	0.24	B710

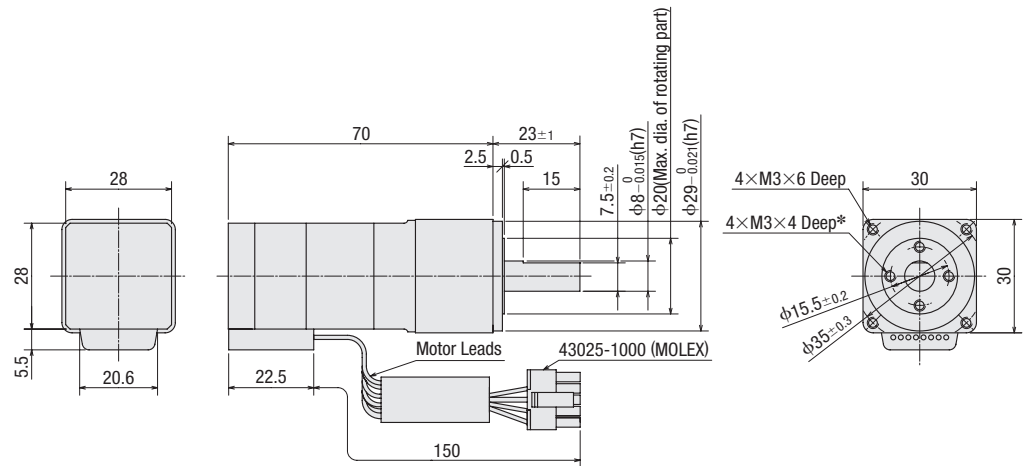

\*The position of the output shaft relative to the screw holes on the rotating part is arbitrary.

● A number indicating the gear ratio is entered where the box  $\blacksquare$  is located within the product name.

● A number indicating the desired length of **1** (1 m), **2** (2 m) or **3** (3 m) for the cable included with the product is entered where the box ◇ is located within the product name.

Features

Lineup

System Configuration

Product Line

Specifications and Characteristics

Dimension

Connection and Operation

Combination List

Extended Functions

How to Read Specifications and Characteristics

Accessory

Controller

### Frame Size 42 mm

Product Name		Motor Product Name	Gear Ratio	Mass kg	CAD
Built-in Controller	Pulse Input				
<b>AR46SAKD-H</b> ■-◇	<b>AR46SAK-H</b> ■-◇	ARM46SAK-H■	<b>50, 100</b>	0.65	B754

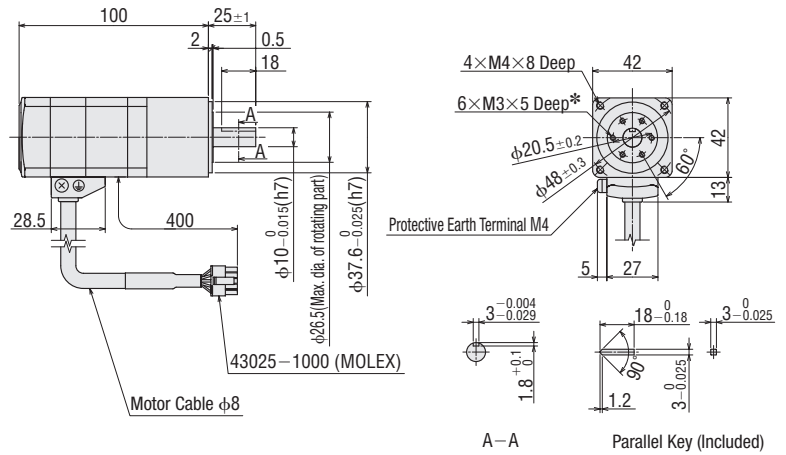

\*The position of the output shaft relative to the screw holes on the rotating part is arbitrary.

### Frame Size 60 mm

Product Name		Motor Product Name	Gear Ratio	Mass kg	CAD
Built-in Controller	Pulse Input				
<b>AR66SAKD-H</b> ■-◇	<b>AR66SAK-H</b> ■-◇	ARM66SAK-H■	<b>50, 100</b>	1.38	B755

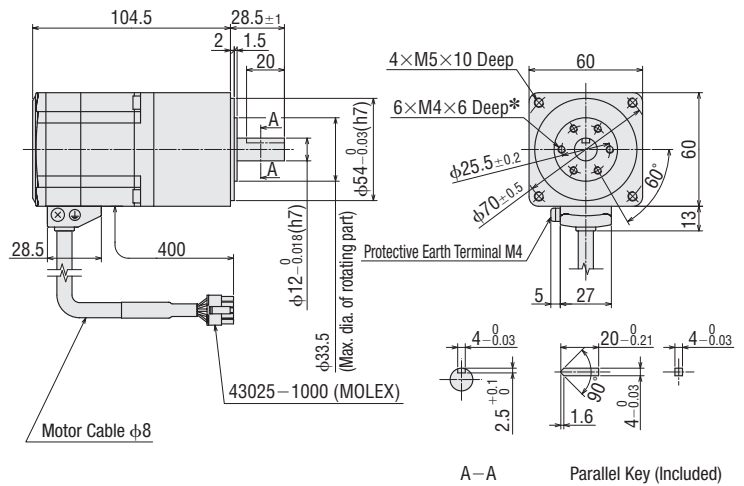

\*The position of the output shaft relative to the screw holes on the rotating part is arbitrary.

● A number indicating the gear ratio is entered where the box ■ is located within the product name.

● A number indicating the desired length of 1 (1 m), 2 (2 m) or 3 (3 m) for the cable included with the product is entered where the box ◇ is located within the product name.

### Frame Size 90 mm

Product Name		Motor Product Name	Gear Ratio	Mass kg	CAD
Built-in Controller	Pulse Input				
<b>AR98SAKD-H</b> ■-◇	<b>AR98SAK-H</b> ■-◇	ARM98SAK-H■	<b>50, 100</b>	3.9	B756

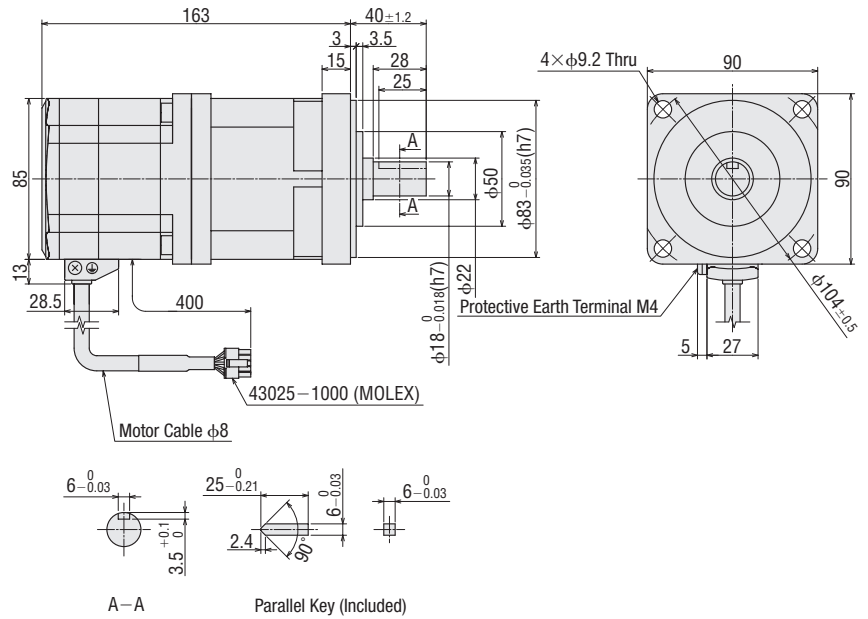

### ◇ Harmonic Geared Type with Electromagnetic Brake Frame Size 42 mm

Product Name		Motor Product Name	Gear Ratio	Mass kg	CAD
Built-in Controller	Pulse Input				
<b>AR46SMKD-H</b> ■-◇	<b>AR46SMK-H</b> ■-◇	ARM46SMK-H■	<b>50, 100</b>	0.78	B757

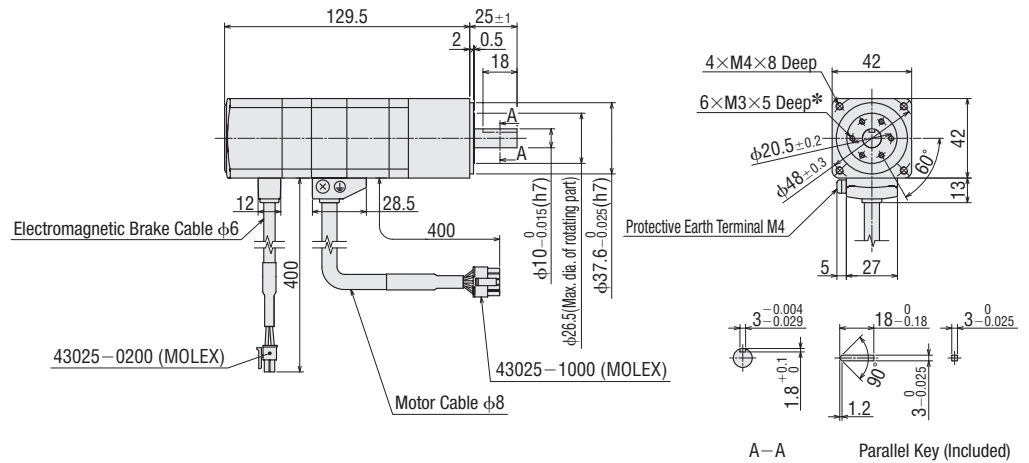

\* The position of the output shaft relative to the screw holes on the rotating part is arbitrary.

● A number indicating the gear ratio is entered where the box ■ is located within the product name.  
 ● A number indicating the desired length of 1 (1 m), 2 (2 m) or 3 (3 m) for the cable included with the product is entered where the box ◇ is located within the product name.

Features

Lineup

System Configuration

Product Line

Specifications and Characteristics

Dimension

Connection and Operation

Combination List

Extended Functions

How to Read Specifications and Characteristics

Accessory

Controller

### Frame Size 60 mm

Product Name		Motor Product Name	Gear Ratio	Mass kg	CAD
Built-in Controller	Pulse Input				
<b>AR66SMKD-H</b> ■-◇	<b>AR66SMK-H</b> ■-◇	ARM66SMK-H■	<b>50, 100</b>	1.64	B758

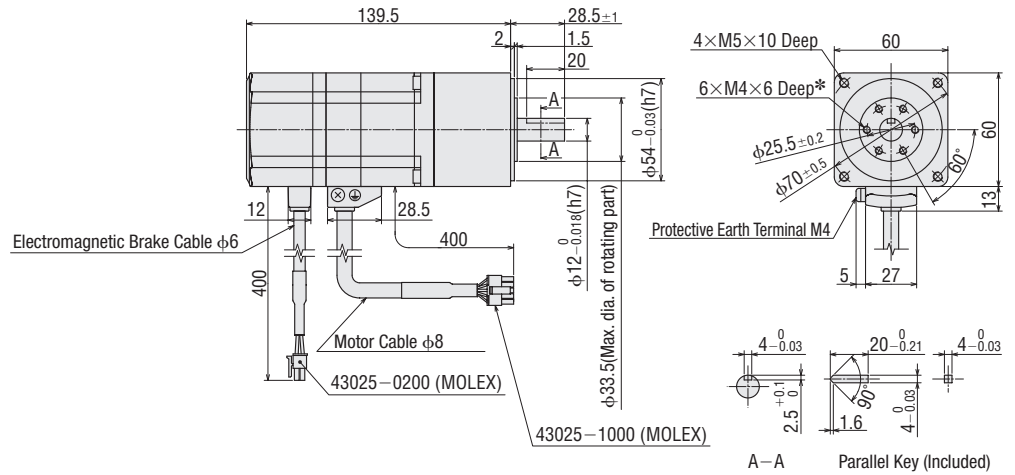

\*The position of the output shaft relative to the screw holes on the rotating part is arbitrary.

### Frame Size 90 mm

Product Name		Motor Product Name	Gear Ratio	Mass kg	CAD
Built-in Controller	Pulse Input				
<b>AR98SMKD-H</b> ■-◇	<b>AR98SMK-H</b> ■-◇	ARM98SMK-H■	<b>50, 100</b>	4.4	B759

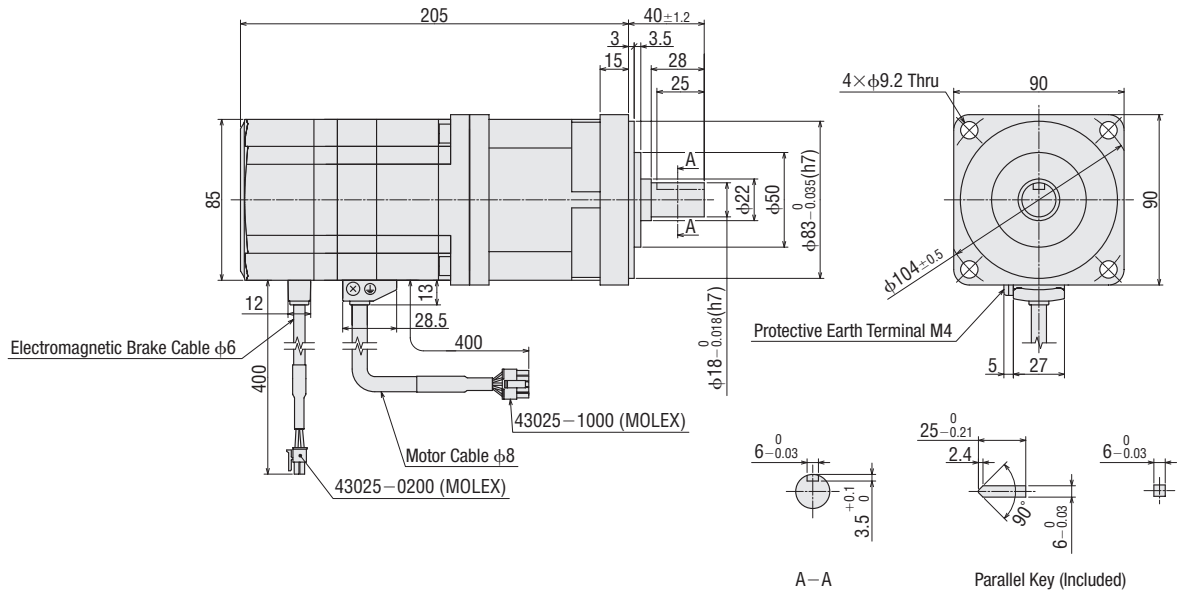

● A number indicating the gear ratio is entered where the box ■ is located within the product name.

● A number indicating the desired length of 1 (1 m), 2 (2 m) or 3 (3 m) for the cable included with the product is entered where the box ◇ is located within the product name.

● Cables for Motor (Included), Cables for Electromagnetic Brake (Included)

Common to All Types

● Cable for Motor

Cable Type	Length L (m)
Cable for Motor 1 m	1
Cable for Motor 2 m	2
Cable for Motor 3 m	3

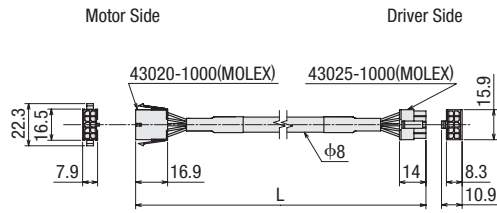

● Cables for Electromagnetic Brake (Electromagnetic brake type only)

Cable Type	Length L (m)
Cable for Electromagnetic Brake 1 m	1
Cable for Electromagnetic Brake 2 m	2
Cable for Electromagnetic Brake 3 m	3

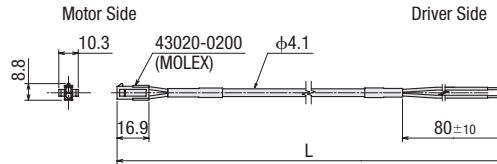

● Driver

Built-in Controller Type

Mass: 0.17 kg CAD B711

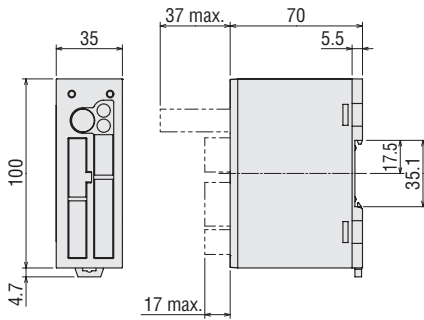

● Included

- Power Input Terminal Connector (CN1)  
Connector: MC1,5/5-STF-3,5 (PHOENIX CONTACT Inc.)
- Sensor Signal Connector (CN5)  
Connector: FK-MC0,5/5-ST-2,5 (PHOENIX CONTACT Inc.)
- Input Signal Connector (CN8)  
Connector: FK-MC0,5/9-ST-2,5 (PHOENIX CONTACT Inc.)
- Output Signal Connector (CN9)  
Connector: FK-MC0,5/7-ST-2,5 (PHOENIX CONTACT Inc.)

Pulse Input Type

Mass: 0.17 kg CAD B546

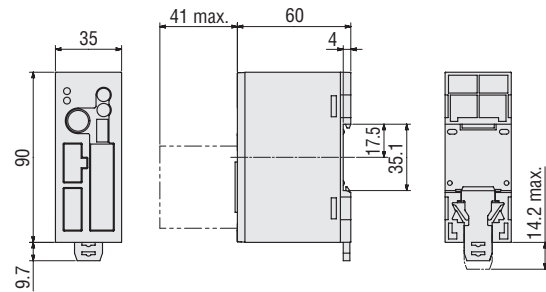

● Included

- Control I/O Signal Connector (CN5)  
Case: 10336-52A0-008 (SUMITOMO 3M)  
Connector: 10136-3000PE (SUMITOMO 3M)
- Power Supply Input and Frame Ground Terminal Connector (CN1)  
Connector: MC1,5/3-STF-3,5 (PHOENIX CONTACT Inc.)

Features

Lineup

System Configuration

Product Line

Specifications and Characteristics

Dimension

Connection and Operation

Combination List

Extended Functions

How to Read Specifications and Characteristics

Accessory

Controller

## Connection and Operation (Built-in controller type)

### Names and Functions of Driver Parts

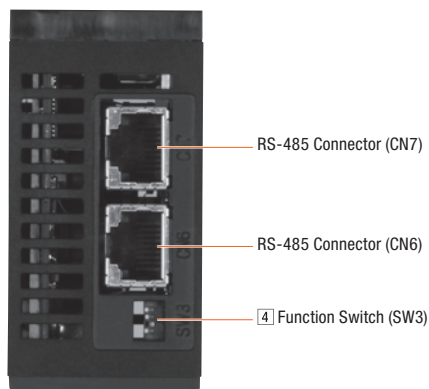

[Driver Top]

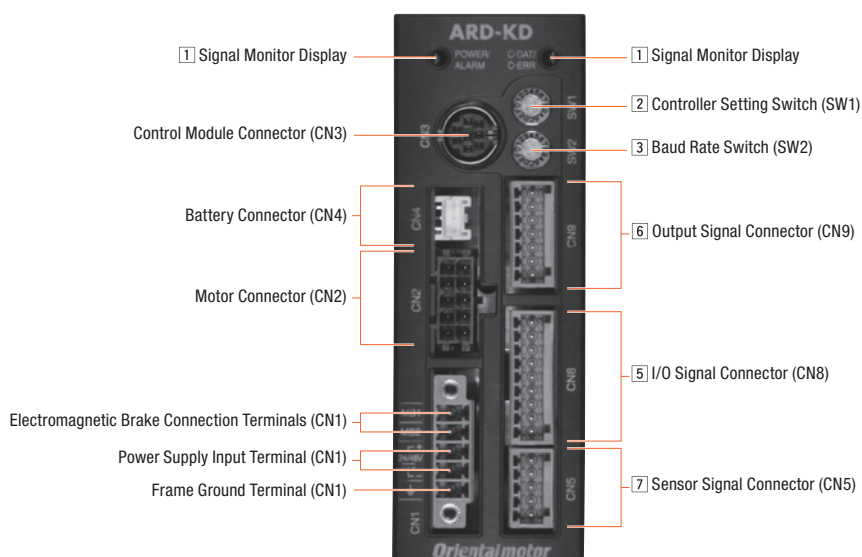

#### 1 Signal Monitor Display

##### ◇ LED Indicator

Indication	Color	Function	Lighting Condition
POWER	Green	Power Supply Indication	When the power supply is input
ALARM	Red	Alarm Indication	Blinks when protective functions are activated.
C-DAT	Green	Communication Indication	When communication data is being exchanged
C-ERR	Red	Communication Error Indication	When communication data is in error

#### 2 Controller Setting Switch (SW1)

Indication	Function
SW1	Set this when you are using RS-485 communication. Set the controller number (Factory Setting: 0).

#### 3 Baud Rate Switch (SW2)

Indication	Function
SW2	Set this when you are using RS-485 communication. Set the baud rate (Factory Setting: 7).

##### ◇ RS-485 Baud Rate Setting

No.	Baud Rate (bps)
0	9600
1	19200
2	38400
3	57600
4	115200
5~6	Not used
7	625000 (Connection with a network converter)
8~F	Not used

#### 4 Function Switch (SW3)

Indication	No.	Function
SW3	1	Set the controller number (Factory Setting: 0) in combination with Controller Setting Switch (SW1).
	2	Set the RS-485 protocol (Factory Setting: OFF).
	3	Not used.
	4	Set the RS-485 termination (120Ω) (Factory Setting: OFF). OFF: Termination disabled ON: Termination enabled

#### ◇ RS-485 Protocol Setting

Destination No.	Connection with a network converter	Modbus RTU Mode
2	OFF	ON

#### 5 I/O Signal Connector (CN8)

Indication	Pin No.	Signal Name	Initial Value
CN8	1	IN0	HOME Executes a return-to-home operation.
	2	IN1	START Executes a positioning operation.
	3	IN2	M0
	4	IN3	M1
	5	IN4	M2
	6	IN5	FREE Stop motor excitation and release the electromagnetic brake.
	7	IN6	STOP Stops the motor.
	8	IN7	ALM-RST Resets the current alarm.

● Assign functions by setting parameters. Initial values are shown above. For details, refer to the user's manual.

The following input signals can be assigned to input terminals IN0 to 7.

Input Signal				
0: Not used	8: MS0	18: STOP	36: R4	45: R13
1: FWD	9: MS1	24: ALM-RST	37: R5	46: R14
2: RVS	10: MS2	25: P-PRESET	38: R6	47: R15
3: HOME	11: MS3	26: P-CLR	39: R7	48: M0
4: START	12: MS4	27: HMI	40: R8	49: M1
5: SSTART	13: MS5	32: R0	41: R9	50: M2
6: +JOG	16: FREE	33: R1	42: R10	51: M3
7: -JOG	17: C-ON	34: R2	43: R11	52: M4
		35: R3	44: R12	53: M5

#### 6 Output Signal Connector (CN9)

Indication	Pin No.	Signal Name	Initial Value
CN9	1	OUT0	HOME-P This signal is output when the motor is at the home position.
	2	OUT1	END This signal is output when the positioning operation is complete.
	3	OUT2	AREA1 This signal is output when the motor is in area 1.
	4	OUT3	READY This signal is output when the driver is ready.
	5	OUT4	WNG This output signal indicates the driver warning status.
	6	OUT5	ALM This output signal indicates the driver alarm status (normally closed).

● Assign functions by setting parameters. Initial values are shown above. For details, refer to the user's manual.

The following output signals can be assigned to output terminals OUT0 to 5.

Output Signal					
0: Not used	9: MS1_R	33: R1	42: R10	51: M3_R	67: READY
1: FWD_R	10: MS2_R	34: R2	43: R11	52: M4_R	68: MOVE
2: RVS_R	11: MS3_R	35: R3	44: R12	53: M5_R	69: END
3: HOME_R	12: MS4_R	36: R4	45: R13	60: +LS_R	70: HOME-P
4: START_R	13: MS5_R	37: R5	46: R14	61: -LS_R	71: TLC
5: SSTART_R	16: FREE_R	38: R6	47: R15	62: HOMES_R	72: TIM
6: +JOG_R	17: C-ON_R	39: R7	48: M0_R	63: SLIT_R	73: AREA1
7: -JOG_R	18: STOP_R	40: R8	49: M1_R	65: ALM	74: AREA2
8: MS0_R	32: R0	41: R9	50: M2_R	66: WNG	75: AREA3
					80: S-BSY

#### 7 Sensor Signal Input (CN5)

Indication	Pin No.	Signal Name	Initial Value
CN5	1	+LS	+side limit sensor input
	2	-LS	-side limit sensor input
	3	HOMES	Mechanical home sensor input
	4	SLIT	Slit Sensor Input
	5	IN-COM2	Sensor common

● Connection Diagram

- ◇ Connection to Programmable Controller
- Connecting to a Current Sink Output Circuit

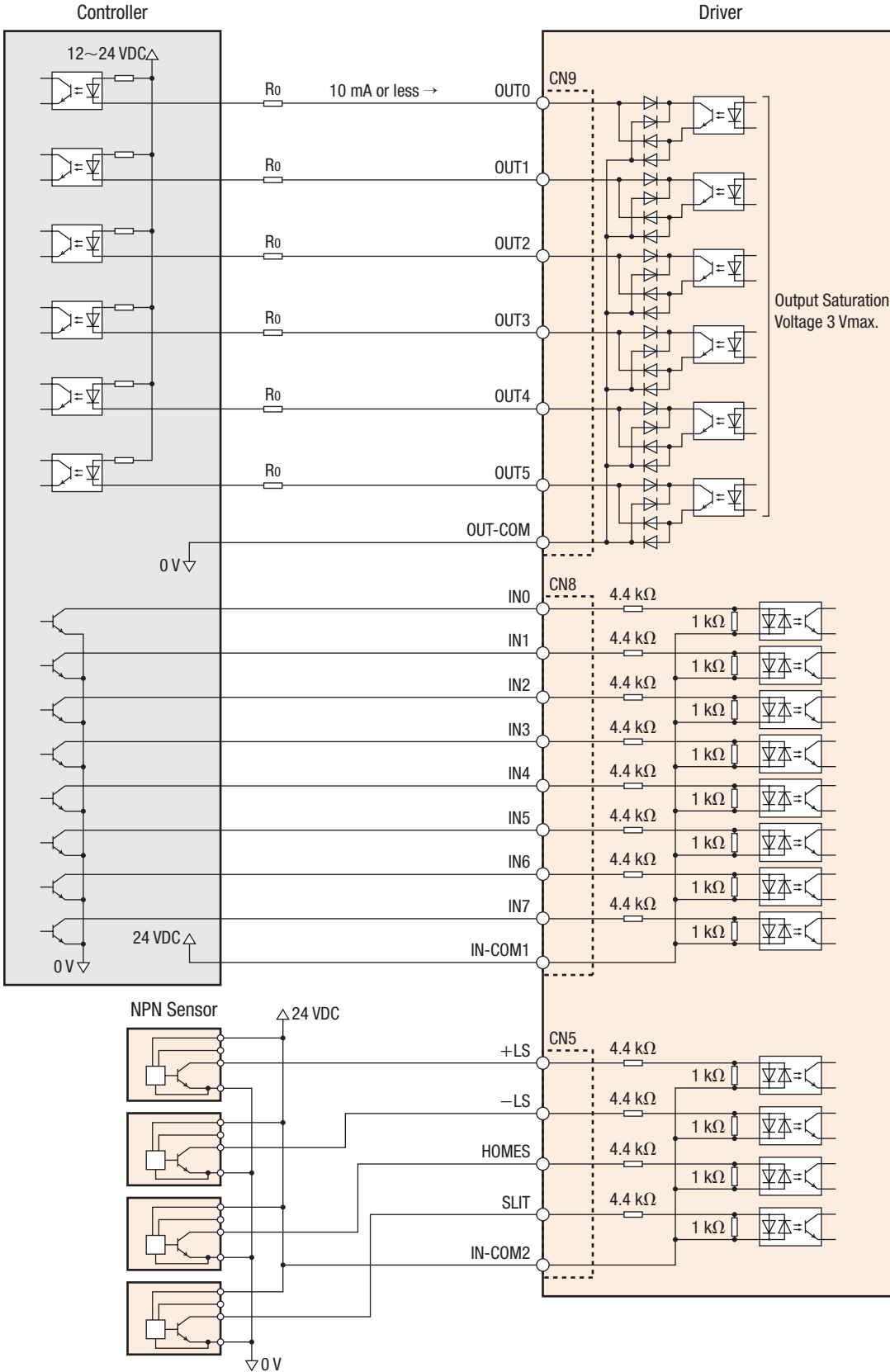

Note

- Use 24 VDC input signals.
- Use 24 VDC output signals at 10 mA or less. When the current value exceeds 10 mA, connect the external resistor  $R_o$  to keep the current 10 mA or less.
- The maximum output signal saturation voltage is 3 V.
- Provide a distance of at least 200 mm between the signal lines and power lines (power supply lines, motor lines, etc.).  
Do not run the signal lines in the same duct as power lines or bundle them with power lines.
- If noise generated by the motor cable or power supply cable causes a problem with the specific wiring or layout, shield the cable or use ferrite cores.

◇ Connection to Programmable Controller

● Connecting to a Current Source Output Circuit

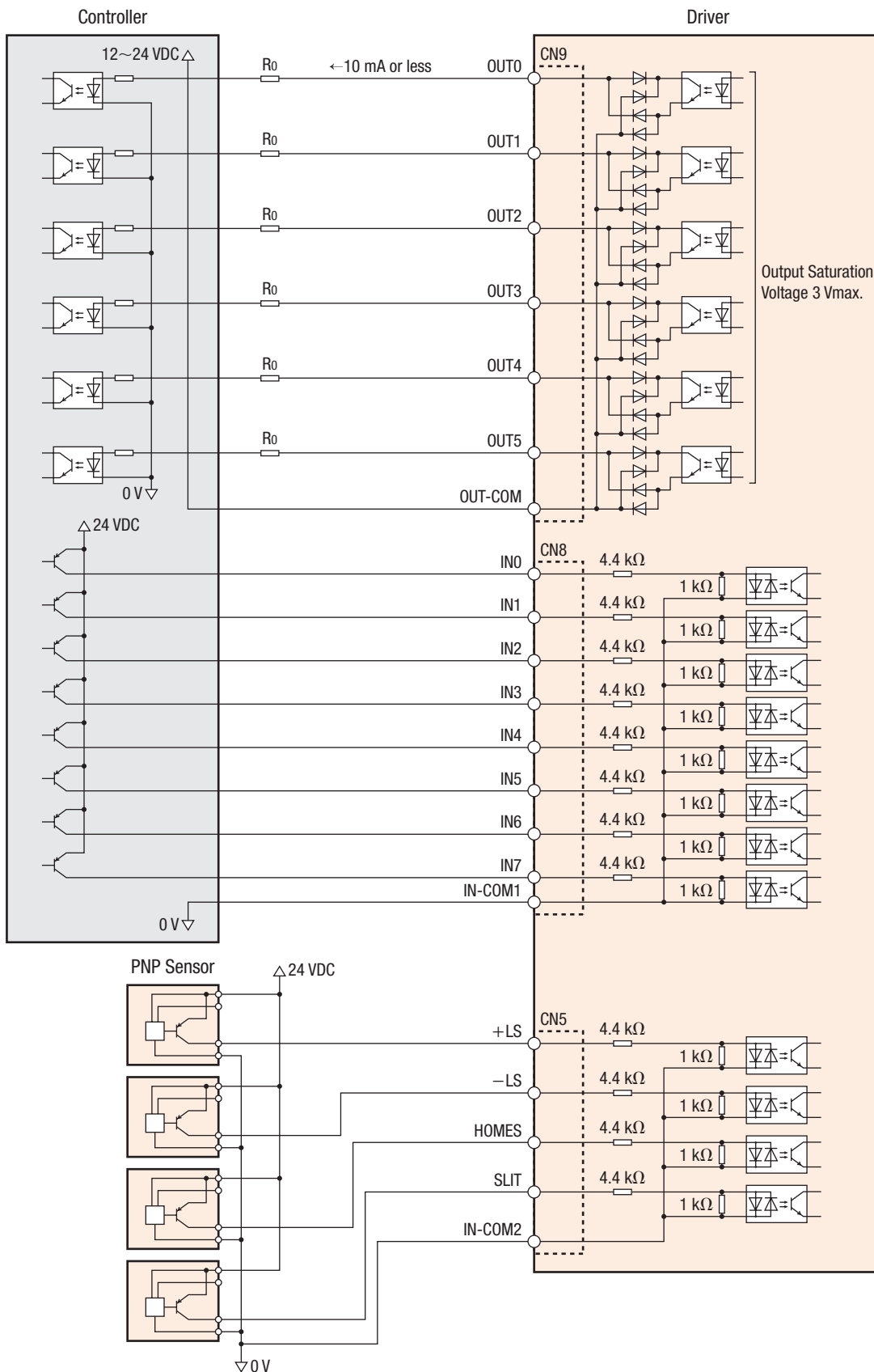

Note

- Use 24 VDC input signals.
- Use 24 VDC output signals at 10 mA or less. When the current value exceeds 10 mA, connect the external resistor  $R_o$  to keep the current 10 mA or less.
- The maximum output signal saturation voltage is 3 V.
- Provide a distance of at least 200 mm between the signal lines and power lines (power supply lines, motor lines, etc.).  
Do not run the signal lines in the same duct as power lines or bundle them with power lines.
- If noise generated by the motor cable or power supply cable causes a problem with the specific wiring or layout, shield the cable or use ferrite cores.

Features
Lineup
System Configuration
Product Line
Specifications and Characteristics
Dimension
Connection and Operation
Combination List
Extended Functions
How to Read Specifications and Characteristics
Accessory
Controller

## Connection and Operation (Pulse input type)

### Names and Functions of Driver Parts

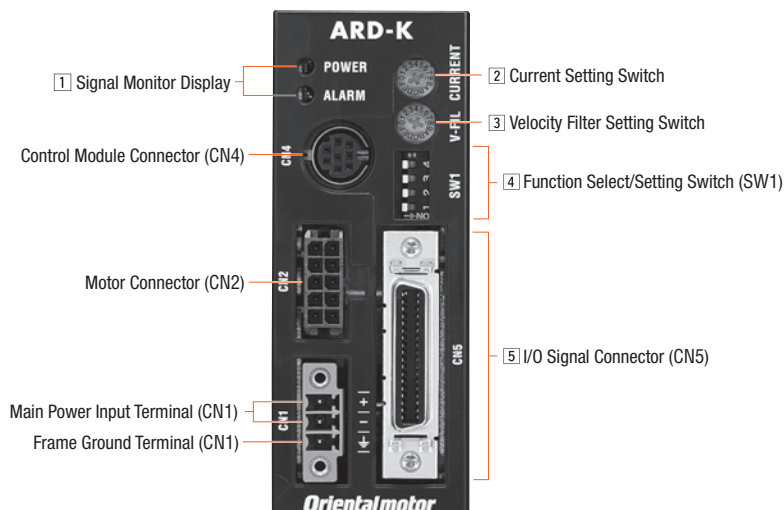

#### 1 Signal Monitor Display

##### ◇ LED Indicator

Indication	Color	Function	Lighting Condition
POWER	Green	Power Supply Indication	When the main power supply is input
ALARM	Red	Alarm Indication	Blinks when protective functions are activated.

##### ◇ Alarm Contents

Blink Count	Function	Operating Condition
2	Overheat Protection	When the temperature inside the driver exceeds 85°C
	Overload	When the amount of time during which the load torque exceeded the maximum torque exceeds the overload detection time. (Default Value: 5 seconds)
	Overspeed	The motor output shaft speed exceeds 4500 r/min.
	Command Pulse Error	The command pulse value becomes abnormal.
3	Overvoltage Protection	The primary voltage of the driver's inverter exceeds the upper limit.
	Undervoltage	The primary voltage of the driver's inverter drops below the lower limit.
4	Excessive Positioning Deviation Error at Current On	The positioning deviation exceeds the overflow revolutions. (Default Value: 3 revolutions)
	Excessive Positioning Deviation Error at Current Off	The current is turned on even though the positioning deviation when the current is turned off was equal to or greater than the permissible value. (Default Value: 100 revolutions or more)
7	Operation Data Error	Return to electrical home operation is performed while an operation data error warning is present.
	Electronic Gear Setting Error	The resolution set by the electronic gear is outside the specified range.
8	Sensor Error during Operation	A sensor error occurs while the motor is rotating.
	Initial Sensor Error	The power source is turned on when the motor cable is not connected to the driver.
	Initial Rotor Revolution Error	The main power supply is turned on while the motor is rotating.
	Motor Combination Error	A motor not supported by the driver is connected.
9	EEPROM Error	A motor control parameter is damaged.

#### 2 Current Setting Switch

Indication	Switch Name	Function
CURRENT	Current Setting Switch	This switch adjusts the operating current. It is used to limit the torque and temperature rise. A desired current can be set as a percentage (%) of the rated output power current. Factory Setting: F

#### 3 Velocity Filter Setting Switch

Indication	Switch Name	Function
V-FIL	Velocity Filter Setting Switch	This switch adjusts the motor response. Adjust the switch if you want to suppress motor vibration or cause the motor to start/stop smoothly. "0" and "F" correspond to the minimum and maximum velocity filter settings, respectively. Factory Setting: 1

Difference in Characteristics Due to Velocity Filter

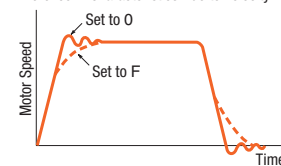

#### 4 Function Select/Setting Switch (SW1)

Indication	Switch Name	Function
4	Resolution Select Switch D0/D1 CS0/CS1	These switches are used to set the resolution per rotation of the motor output shaft. 4: OFF, 3: OFF → 1000 pulses (0.36°/step) [Factory setting] 4: OFF, 3: ON → 10000 pulses (0.036°/step) 4: ON, 3: OFF → 500 pulses (0.72°/step) 4: ON, 3: ON → 5000 pulses (0.072°/step)
3		
2	Control Modes Select Switch NORM/CCM	This switch toggles the driver between the normal mode and current control mode. In the current control mode, noise and vibration can be reduced although the motor synchronicity may reduce. OFF: Normal Mode [Factory setting] ON: Current Control Mode
1	Pulse Input Mode Select Switch 2P/1P	This switch toggles the pulse input mode between 1-pulse input mode and 2-pulse input mode. OFF: 2-Pulse Input Mode [Factory setting] ON: 1-Pulse Input Mode

#### 5 I/O Signal Connector (CN5, 36 pins)

Indication	I/O	Pin No.	Code		Signal Name	
			Positioning Operation	Push-Motion Operation*1	Positioning Operation	Push-Motion Operation*1
CN5	Output Power	1	—	—	—	—
		2	GND	—	Ground connection	—
		3	ASG+	—	A-Phase Pulse Output Signal (Line driver)	—
		4	ASG—	—	—	—
		5	BSG+	—	B-Phase Pulse Output Signal (Line driver)	—
		6	BSG—	—	—	—
		7	TIM1+	—	Timing Output (Line driver)	—
		8	TIM1—	—	—	—
		9	ALM+	—	Alarm Output	—
		10	ALM—	—	—	—
		11	WNG+	—	Warning Output	—
		12	WNG—	—	—	—
		13	END+	—	Positioning Completion Output	—
		14	END—	—	—	—
		15	READY+/AL0+*1	—	Operation Ready Complete Output/Alarm Code 0 Output*1	—
		16	READY-/AL0-*1	—	—	—
		17	TLC+/AL1+*1	—	Torque Limiting Output/Alarm Code 1 Output*1	—
		18	TLC-/AL1-*1	—	—	—
		19	TIM2+/AL2+*1	—	Timing Output (Open collector)/Alarm Code 2 Output*1	—
		20	TIM2-/AL2-*1	—	—	—
	21	GND	—	Ground connection	—	
	Input	22	IN—COM	—	Input Signal Common	—
		23	C—ON*2	—	Current On Input*2	—
		24	CLR/ALM—RST	—	Deviation Counter Clear Input/Alarm Reset Input	—
		25	CCM	—	Current Control Mode ON Input	—
		26	CS	T—MODE*1	Resolution Select Input	Push-Motion Operation ON*1
		27	—	M0*1	—	—
		28	RETURN	M1*1	Return To Electrical Home Operation	Push-Current Setting Select Input*1
		29	P—RESET	M2*1	Position Reset Input	—
		30	FREE	—	Excitation OFF	—
		31	CW+/PLS+	—	CW Pulse Signal Input/Pulse Input (+5 V/line driver)	—
		32	CW-/PLS—	—	—	—
		33	CW+24/PLS+24V	—	CW Pulse Signal Input/Pulse Input (+24 V)	—
		34	CCW+24/DIR+24V	—	CCW Pulse Signal Input/Rotation Direction Input (+24 V)	—
		35	CCW+/DIR+	—	CCW Pulse Signal Input/Rotation Direction Input (+5 V/line driver)	—
		36	CCW-/DIR—	—	—	—

\*1 The signal will become effective if the applicable setting has been changed using the accessory control module **OPX-2A** or data setting software **MEXE02** (both sold separately).

\*2 The factory setting of current ON input is normally open. When operating the motor, be sure to turn the current ON input "ON." If you are not using the current ON input, use the accessory control module **OPX-2A** or data setting software **MEXE02** to set the input logic to normally closed.

● Connection Diagram

◇ Connection to Programmable Controller

● Connecting to a Current Sink Output Circuit

When pulse input is of line driver type

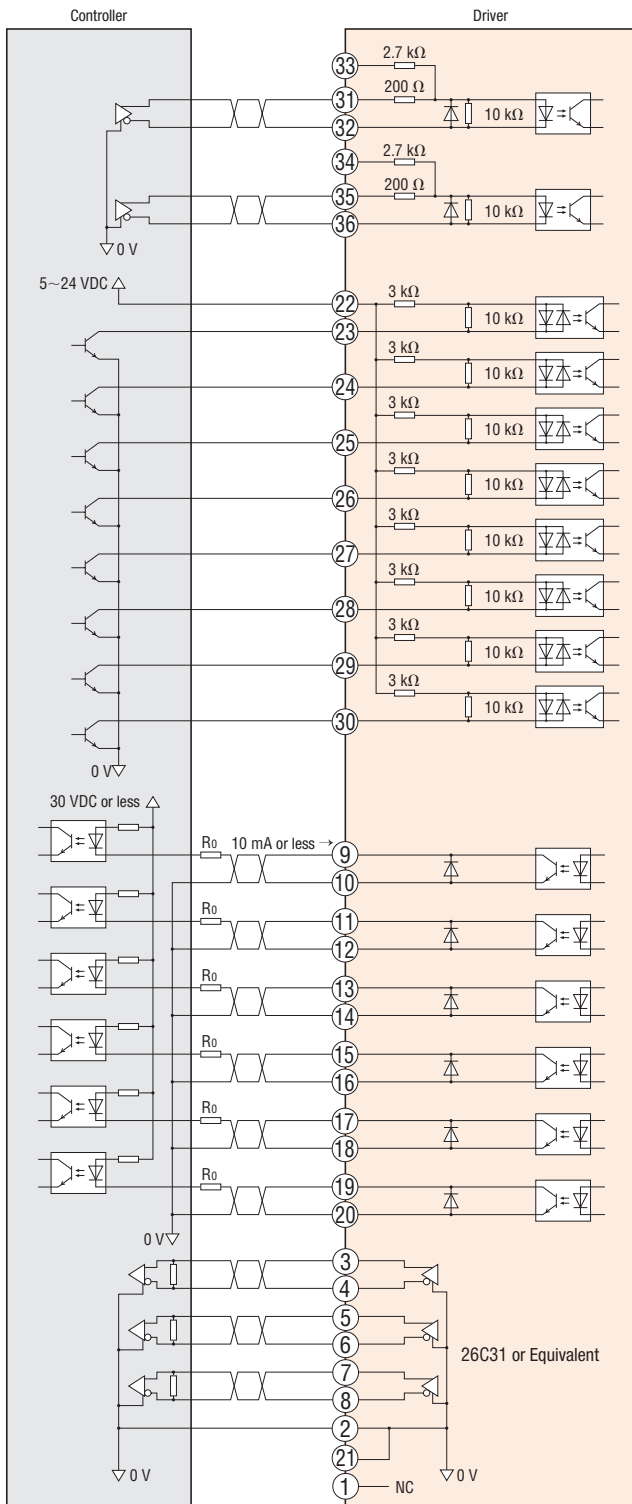

When pulse input is of 5 V type

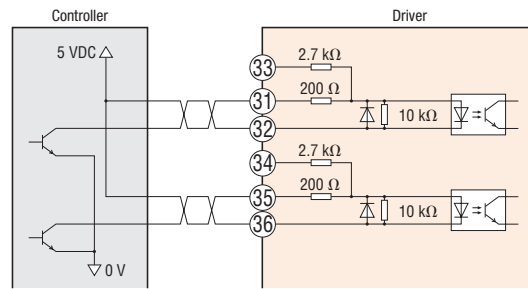

When pulse input is of 24 V type

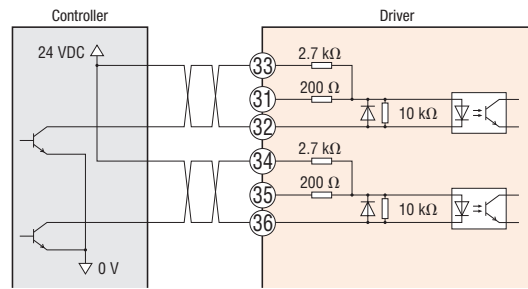

**Note**

- Use 30 VDC or less for the output signals. When the current value exceeds 10 mA, connect the external resistor  $R_o$ .
- Connect a termination resistor of 100  $\Omega$  or more between the line receiver inputs.
- Use multi-core, twisted-pair shielded wires of AWG 28~24 (0.08~0.2 mm<sup>2</sup>) for the I/O signal lines (CN5), and keep wiring as short as possible (within 2 m).
- Note that as the length of the pulse signal line increases, the maximum transmission frequency decreases.
- Provide a distance of 200 mm min. between the I/O signal lines and power lines (AC lines, motor lines and other large-current circuits).

◇ Connection to Programmable Controller

● Connecting to a Current Source Output Circuit

When pulse input is of line driver type

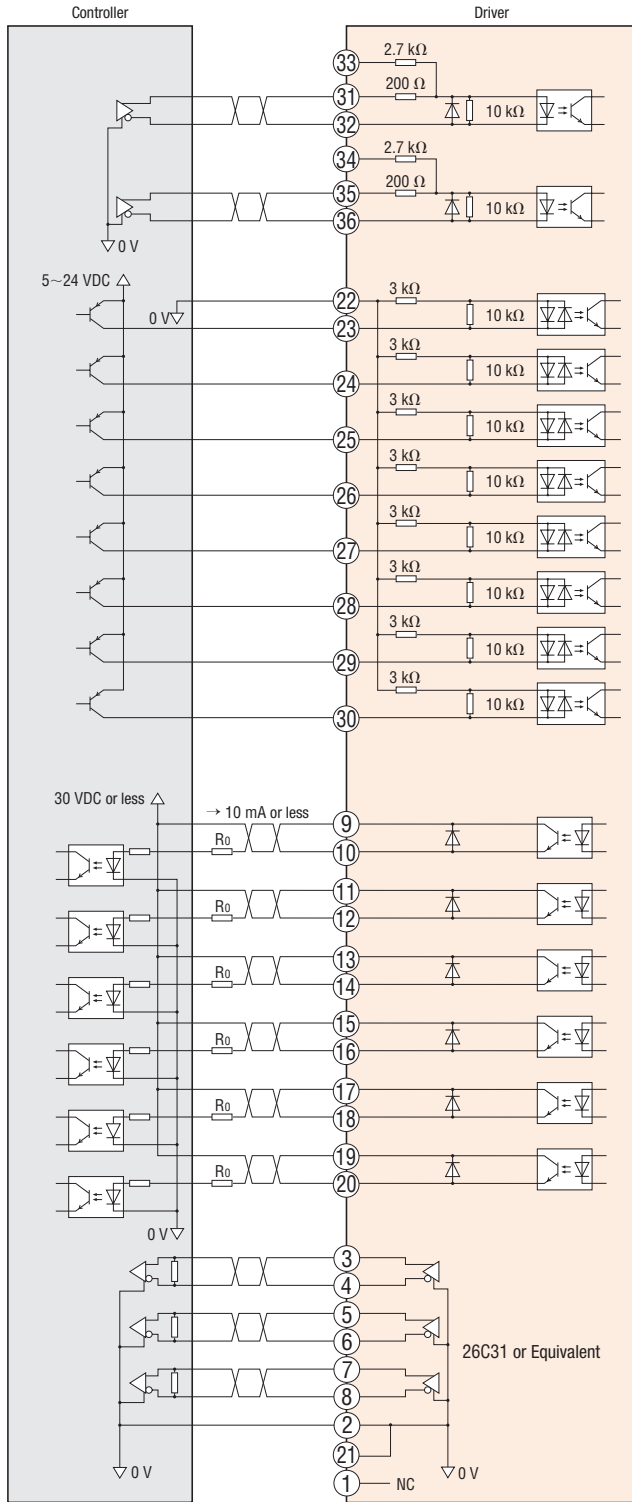

When pulse input is of 5 V type

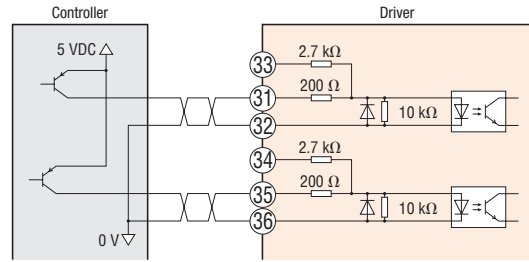

When pulse input is of 24 V type

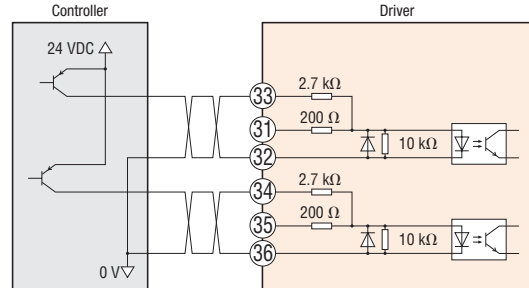

**Note**

- Use 30 VDC or less for the output signals. When the current value exceeds 10 mA, connect the external resistor  $R_0$ .
- Connect a termination resistor of 100 Ω or more between the line receiver inputs.
- Use multi-core, twisted-pair shielded wires of AWG 28~24 (0.08~0.2 mm<sup>2</sup>) for the I/O signal lines (CN5), and keep wiring as short as possible (within 2 m).
- Note that as the length of the pulse signal line increases, the maximum transmission frequency decreases.
- Provide a distance of 200 mm min. between the I/O signal lines and power lines (AC lines, motor lines and other large-current circuits).

## Motor and Driver Combinations

Product names for motor and driver combinations are shown below.

Type	Built-in Controller Type			Pulse Input Type		
	Product Name	Motor Product Name	Driver Product Name	Product Name	Motor Product Name	Driver Product Name
Standard Type	<b>AR24S</b> □ <b>KD</b> -◇*1	ARM24S□K	ARD-KD	<b>AR24S</b> □ <b>K</b> -◇*1	ARM24S□K	ARD-K
	<b>AR26S</b> □ <b>KD</b> -◇*1	ARM26S□K		<b>AR26S</b> □ <b>K</b> -◇*1	ARM26S□K	
	<b>AR46S</b> □ <b>KD</b> -◇*2	ARM46S□K		<b>AR46S</b> □ <b>K</b> -◇*2	ARM46S□K	
	<b>AR66S</b> □ <b>KD</b> -◇*2	ARM66S□K		<b>AR66S</b> □ <b>K</b> -◇*2	ARM66S□K	
	<b>AR69S</b> □ <b>KD</b> -◇*2	ARM69S□K		<b>AR69S</b> □ <b>K</b> -◇*2	ARM69S□K	
<b>AR98S</b> □ <b>KD</b> -◇*2	ARM98S□K	<b>AR98S</b> □ <b>K</b> -◇*2		ARM98S□K		
TH Geared Type	<b>AR24SAKD-T</b> ■-◇	ARM24SAK-T■		<b>AR24SAK-T</b> ■-◇	ARM24SAK-T■	
	<b>AR46S</b> □ <b>KD-T</b> ■-◇	ARM46S□K-T■		<b>AR46S</b> □ <b>K-T</b> ■-◇	ARM46S□K-T■	
	<b>AR66S</b> □ <b>KD-T</b> ■-◇	ARM66S□K-T■		<b>AR66S</b> □ <b>K-T</b> ■-◇	ARM66S□K-T■	
	<b>AR98S</b> □ <b>KD-T</b> ■-◇	ARM98S□K-T■		<b>AR98S</b> □ <b>K-T</b> ■-◇	ARM98S□K-T■	
PS Geared Type	<b>AR24SAKD-PS</b> ■-◇	ARM24SAK-PS■		<b>AR24SAK-PS</b> ■-◇	ARM24SAK-PS■	
	<b>AR46S</b> □ <b>KD-PS</b> ■-◇	ARM46S□K-PS■		<b>AR46S</b> □ <b>K-PS</b> ■-◇	ARM46S□K-PS■	
	<b>AR66S</b> □ <b>KD-PS</b> ■-◇	ARM66S□K-PS■		<b>AR66S</b> □ <b>K-PS</b> ■-◇	ARM66S□K-PS■	
	<b>AR98S</b> □ <b>KD-PS</b> ■-◇	ARM98S□K-PS■		<b>AR98S</b> □ <b>K-PS</b> ■-◇	ARM98S□K-PS■	
PN Geared Type	<b>AR24SAKD-N</b> ■-◇	ARM24SAK-N■		<b>AR24SAK-N</b> ■-◇	ARM24SAK-N■	
	<b>AR46S</b> □ <b>KD-N</b> ■-◇	ARM46S□K-N■	<b>AR46S</b> □ <b>K-N</b> ■-◇	ARM46S□K-N■		
	<b>AR66S</b> □ <b>KD-N</b> ■-◇	ARM66S□K-N■	<b>AR66S</b> □ <b>K-N</b> ■-◇	ARM66S□K-N■		
	<b>AR98S</b> □ <b>KD-N</b> ■-◇	ARM98S□K-N■	<b>AR98S</b> □ <b>K-N</b> ■-◇	ARM98S□K-N■		
Harmonic Geared Type	<b>AR24SAKD-H</b> ■-◇	ARM24SAK-H■	<b>AR24SAK-H</b> ■-◇	ARM24SAK-H■		
	<b>AR46S</b> □ <b>KD-H</b> ■-◇	ARM46S□K-H■	<b>AR46S</b> □ <b>K-H</b> ■-◇	ARM46S□K-H■		
	<b>AR66S</b> □ <b>KD-H</b> ■-◇	ARM66S□K-H■	<b>AR66S</b> □ <b>K-H</b> ■-◇	ARM66S□K-H■		
	<b>AR98S</b> □ <b>KD-H</b> ■-◇	ARM98S□K-H■	<b>AR98S</b> □ <b>K-H</b> ■-◇	ARM98S□K-H■		

● Either **A** (single shaft) or **M** (electromagnetic brake) indicating the configuration is entered where the box □ is located within the product name.

A number indicating the gear ratio is entered where the box ■ is located within the product name.

A number indicating the desired length of **1** (1 m), **2** (2 m) or **3** (3 m) for the cable included with the product is entered where the box ◇ is located within the product name.

\*1 Either **A** (single shaft) or **B** (double shaft) indicating the motor shaft configuration is entered where the box □ is located within **AR24S**□**K(D)**-◇ and **AR26S**□**K(D)**-◇.

\*2 Either **A** (single shaft), **B** (double shaft), or **M** (electromagnetic brake) indicating the motor shaft configuration is entered where the box □ is located within **AR46S**□**K(D)**-◇, **AR66S**□**K(D)**-◇, **AR69S**□**K(D)**-◇, and **AR98S**□**K(D)**-◇.

# Extended Functions

With the accessory control module **OPX-2A** or data setting software **MEXE02**, extended functions of the **AR Series** are available. You can change the internal parameters of the driver, perform test operations and monitor the operation.

Control Module **OPX-2A**  
→ Page 53

Data Setting Software **MEXE02**  
→ Page 54



Computer  
(Not supplied.)

## Parameter Settings (For pulse input type)

You can set the advanced settings of the signals and change the generation condition of the alarm.

Application Parameters	Running Current	Current value assigned to the operating current setting switch	
	Velocity Filter	Filter time constant assigned to the speed filter setting switch	
	I/O	Input signal mode	Positioning operation/push-motion operation switching
		Alarm code signal enabled/disabled	
		C-ON signal logic	
		Output condition for END signal (output width)	
	Normal Mode	Current value applicable to push-motion operation	
		Standstill current in the normal mode	
	Current Control Mode	Speed difference gain in the normal mode	
		Position loop gain in the current control mode	
		Speed loop gain in the current control mode	
		Speed loop integral time constant in the current control mode	
		Damping control enabled/disabled in the current control mode	
	Alarm and Warning	Damping control vibration frequency in the current control mode	
		Operation data error warning enabled/disabled	
		Generation condition of excessive positioning deviation alarm at current on	
		Generation condition of overflow rotation alarm during current off	
		Generation condition of overload alarm	
		Generation condition of excessive positioning deviation warning	
		Generation condition of overvoltage warning	
Generation condition of undervoltage warning			
Generation condition of overheat warning			
Generation condition of overload warning			
Generation condition of overspeed warning			
Return To Electrical Home Operation	Operating speed for return to electrical home operation		
	Acceleration/deceleration rate for return to electrical home operation		
	Starting speed for return to electrical home operation		
Test Operation	Operating speed for test operation		
	Acceleration/deceleration rate for test operation		
	Starting speed for test operation		
Control Module	Speed monitor display	Show the speed on the control module with a sign or as an absolute value	
	Gear ratio for geared motor used for speed monitor		
System Parameters (Becomes effective after the power is cycled.)	Electronic Gear	Resolution assigned to each resolution select switch	
	Operation Setting	Pulse Input Mode	
		Smooth drive enabled/disabled	
		Initial motor excitation position at power on	Detected position/electrical angle 0° switching
		Automatic return operation at current ON enabled/disabled	
Motor rotation direction			

## Monitor

You can monitor various signals, alarms and motor speeds/positions, and also perform test operations.

Monitor	Monitor positions
	Monitor speeds
Waveform Monitoring*	I/O Monitoring
	Monitor positions*
	Monitor speeds*
	Measure waveforms*
Testing	Save waveforms*
	Perform test operation (JOG operation)
	Monitor conditions during test operation
	Return To Electrical Home Operation
Alarm	Forcibly turn output signals ON/OFF
	Check content when generated
	Check alarm history (10 most recent alarms)
	Clear alarm history
Warning	Release
	Check content when generated
	Check alarm history (10 most recent alarms)
	Clear alarm history

\*This function is available only when the data setting software (**MEXE02**) is used.

### Waveform Monitoring

You can monitor various signals and motor speeds/positions using waveforms.

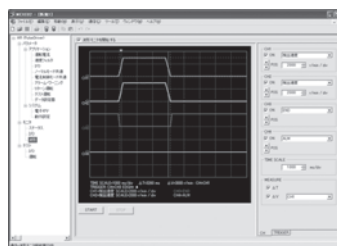

### Others

- Electrical home reset
- Parameter initialization

# How to Read Specifications Table

	Product Name	Built-in Controller	AR46S□KD-◇	AR46S□KD-N5-◇
		Pulse Input	AR46S□K-◇	AR46S□K-N5-◇
①	Maximum Holding Torque	N·m	0.3	1.35
②	Rotor Inertial Moment	J: kg·m <sup>2</sup>	$58 \times 10^{-7} [73 \times 10^{-7}]^{*1}$	$58 \times 10^{-7} [73 \times 10^{-7}]^{*1}$
③	Gear Ratio		—	5
④	Resolution	When Set to 1000P/R	0.36°/Pulse	0.072°/Pulse
⑤	Permissible Torque	N·m	—	1.35
⑥	Maximum Torque	N·m	—	1.5
⑦	Holding Torque at Motor Standstill	While Power is Supplied	N·m	0.15
		Electromagnetic Brake	N·m	0.15
⑧	Permissible Speed Range	r/min	—	0~600
⑨	Backlash	arc minute (degrees)	—	2(0.034°)
⑩	Power Supply Input	Voltage	24 VDC±10% (24 VDC±5%)*2/48 VDC±5%	
		Input Current	A	
		Electromagnetic Brake*3	Power Supply Input	
			24 VDC±5%*4 0.08 A	

\*1 The brackets [ ] indicate the specifications for the electromagnetic brake type.

\*2 The parentheses ( ) indicate the specifications for the built-in controller type.

\*3 For the pulse input type, a separate power supply for the electromagnetic brake is also required.

\*4 If the wiring distance between the motor and driver is extended to 20 m or longer using an accessory cable (sold separately), the 24 VDC±4% specification applies.

## ⑤ Permissible Torque

The permissible torque represents the maximum torque that can be applied continuously to the output gear shaft. For the types other than the **PS**, **PN** and harmonic geared types, the total torque including acceleration and deceleration torque should also not exceed the permissible torque.

## ⑥ Maximum Torque

(**PS** geared, **PN** geared and harmonic geared type only)

This is the max. torque that can be applied to the gear output shaft during acceleration/deceleration such as when an inertial load is started and stopped.

## ⑦ Holding Torque at Motor Standstill

While Power is Supplied: The holding torque when the automatic current cutback function is activated

Electromagnetic Brake: Static friction torque that the electromagnetic brake can generate when stopped (The electromagnetic brake is a power off activated type.)

## ⑧ Permissible Speed Range

This is the range for rotation on the gear output shaft.

## ⑨ Backlash

This is the play of the gear output shaft when the motor shaft is fixed. When positioning in bi-direction, the positioning accuracy is affected.

## ⑩ Power Supply Input

The current value of the power input is the max. input current value. (The input current varies according to the rotation speed.)

## ① Maximum Holding Torque

The maximum holding torque (holding force) the motor has when power (rated current) is being supplied but the motor shaft is not rotating. (With geared types, the value of holding torque considers the permissible strength of the gear.)

## ② Rotor Inertial Moment

This refers to the inertia of rotor inside the motor. This is necessary when the required torque (acceleration torque) for the motor is calculated.

## ③ Gear Ratio

This is the ratio in rotation speed between the input speed from the motor and the speed of the gear output shaft. For example, the gear ratio 10 indicates the input speed from the motor is 10 r/min and the output gear shaft is 1 r/min.

## ④ Resolution

The resolution is the angular distance (in degrees) that the motor moves at the input of one pulse from the driver. It differs depending on the motor structure and excitation mode.

# How to Read Speed – Torque Characteristics

The characteristics diagram below is the characteristics that indicate the relationship between the speed and torque when a stepping motor is driven. The required speed and torque is always used when selecting a stepping motor. On the graph of characteristics, the horizontal axis expresses the speed at motor output shaft while the vertical axis expresses the torque.

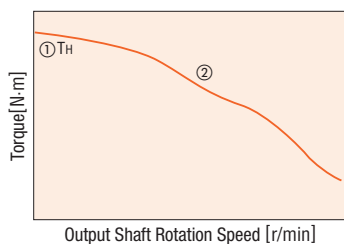

## ① Max. Holding Torque

The maximum holding torque (holding force) the stepping motor has when power (rated current) is being supplied but the motor shaft is not rotating.

## ② Pullout Torque

The pullout torque is the maximum torque that can be output at a given speed. When selecting a motor, ensure that the required torque falls within this curve.

The following figure shows the speed – torque characteristics of **AR66SAK-◇**.

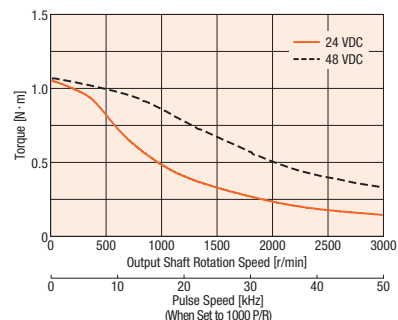

● Depending on the driving conditions, a considerable amount of heat may be generated by the motor. Be sure to keep the temperature of the motor case at approximately 100°C.

# Accessory (Sold separately)

## Control Module RoHS

You can use these to set drivers' internal parameters and set and change data.

You can also use these to set speeds, monitor the I/O, and perform teaching.

### Product Line

Product Name
<b>OPX-2A</b>

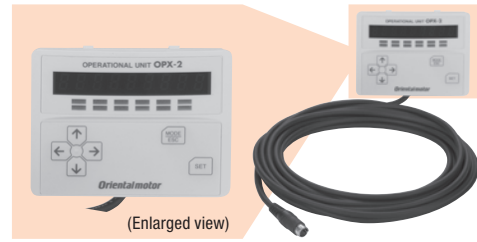

### Dimensions (Unit = mm)

● Control Module  
Mass: 0.25kg CAD B453

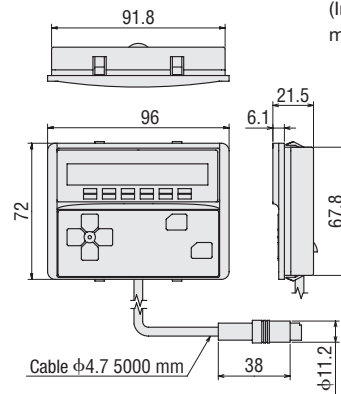

● Panel Cut-Out for Control Module  
(Installation Plate Thickness 1~3 mm)

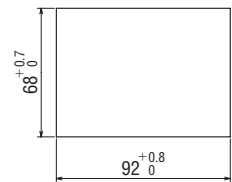

Features

Lineup

System Configuration

Product Line

Specifications and Characteristics

Dimension

Connection and Operation

Combination List

Extended Functions

How to Read Specifications and Characteristics

Accessory

Controller

# Communication Cable for the Data Setting Software RoHS

This cable is required to connect the driver to the PC where the data setting software is installed.

## Product Line

Product Name

**CC05IF-USB**

## PC and Driver Connection

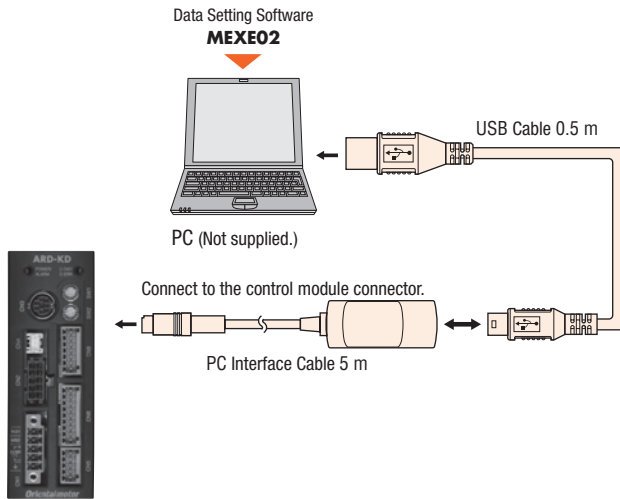

### Note

● To connect the driver to a PC, you must install a dedicated software driver in the PC.

## Data Setting Software MEXE02

The data setting software can be downloaded from our website. It is also available on CD-ROM.

For details, make a request on our website, or contact the nearest Oriental Motor sales office.  
<http://www.orientalmotor.com.sg/>



## PC System Requirements

### Operating System (OS)

- Microsoft Windows 2000 Professional Service Pack 4  
Be sure to install Update Rollup 1 provided by Microsoft. To check whether Update Rollup 1 is installed, use "Add or Remove Programs."

Only the following 32-bit (x86) and 64-bit (x64) OS versions are supported.

- Microsoft Windows XP Home Edition Service Pack 3
- Microsoft Windows XP Professional Service Pack 2
- Microsoft Windows XP Professional Service Pack 3\*
- Microsoft Windows Vista Home Basic Service Pack 2
- Microsoft Windows Vista Home Premium Service Pack 2
- Microsoft Windows Vista Business Service Pack 2
- Microsoft Windows Vista Ultimate Service Pack 2
- Microsoft Windows Vista Enterprise Service Pack 2
- Microsoft Windows 7 Starter Service Pack 1
- Microsoft Windows 7 Home Premium Service Pack 1
- Microsoft Windows 7 Professional Service Pack 1
- Microsoft Windows 7 Ultimate Service Pack 1
- Microsoft Windows 7 Enterprise Service Pack 1

\*32-bit (x86) version only

### PC

Recommended CPU*1	Intel Core processor 2 GHz or higher (Must be compatible with the OS)
Display	Video Adapter and Monitor with Resolution of XGA (1024×768) min.
Recommended Memory*1	32-bit (x86) version: 1 GB or more 64-bit (x64) version: 2 GB or more
Hard Disk*2	Free disk space of 30 MB or more
USB Port	USB1.1 × 1 port
Disk Device	CD-ROM drive (for installing the software)

\*1 Must satisfy the operating requirements of the OS

\*2 **MEXE02** requires Microsoft .NET Framework 2.0 Service Pack 2. When the service pack is not installed, it will automatically be installed. This will require up to 500 MB of additional free space on your PC.

### Note

● Depending on the system environment that you are using, the required memory and hard disk space may vary.

● Windows and Windows Vista are registered trademarks of Microsoft Corporation in the United States and other countries.

# 1 Connection Cable Sets (RoHS), Flexible Connection Cable Sets (RoHS)

# 2 Extension Cable Sets (RoHS), Flexible Extension Cable Sets (RoHS)

The **AR** Series comes with a cable of 1 m, 2 m or 3 m for a connection between the motor and driver.  
When the distance between the motor and driver is extended to 3 m or longer, a connection cable set or extension cable set must be used.  
Use a flexible connection cable set or flexible extension cable set if the cable will be flexed repeatedly.

## System Configuration

### When Connecting the Motor and Driver without Using an Included Cable

Use a connection cable set.  
Use a flexible connection cable set if the cable will be bent.

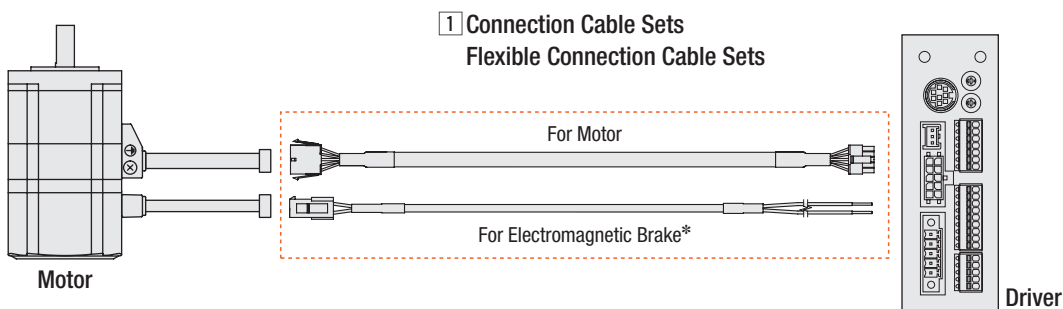

### When Extending the Distance between the Motor and the Driver Using an Included Cable

Use an extension cable set and connect it to the included cable.  
Use a flexible extension cable added if the cable will be bent.

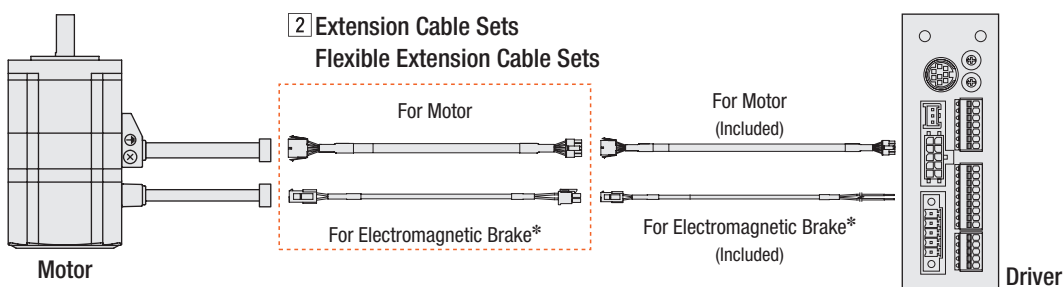

\*Cables for electromagnetic brake are for use when using electromagnetic brake type motors.

#### Note

- Keep the overall cable length 30 m or less when using an extension cable set or a flexible extension cable set to connect with a cable included with the **AR** Series.
- For the pulse input type, a separate power supply for electromagnetic brakes is also required.

# 1 Connection Cable Sets (RoHS), Flexible Connection Cable Sets (RoHS)

## Product Line

- Connection Cable Sets
- ◇ For Standard Type Motor



Cable for Motor

Product Name	Length L (m)
<b>CC050VA2F2</b>	5
<b>CC070VA2F2</b>	7
<b>CC100VA2F2</b>	10
<b>CC150VA2F2</b>	15
<b>CC200VA2F2</b>	20
<b>CC300VA2F2</b>	30

- ◇ For Electromagnetic Brake Type Motor



Cable for Motor

Cable for Electromagnetic Brake

Product Name	Length L (m)
<b>CC050VA2FB2</b>	5
<b>CC070VA2FB2</b>	7
<b>CC100VA2FB2</b>	10
<b>CC150VA2FB2</b>	15
<b>CC200VA2FB2</b>	20
<b>CC300VA2FB2</b>	30

- Flexible Connection Cable Sets
- ◇ For Standard Type Motor



Cable for Motor

Product Name	Length L(m)
<b>CC010VA2R2</b>	1
<b>CC020VA2R2</b>	2
<b>CC030VA2R2</b>	3
<b>CC050VA2R2</b>	5
<b>CC070VA2R2</b>	7
<b>CC100VA2R2</b>	10
<b>CC150VA2R2</b>	15
<b>CC200VA2R2</b>	20
<b>CC300VA2R2</b>	30

- ◇ For Electromagnetic Brake Type Motor



Cable for Motor

Cable for Electromagnetic Brake

Product Name	Length L(m)
<b>CC010VA2RB2</b>	1
<b>CC020VA2RB2</b>	2
<b>CC030VA2RB2</b>	3
<b>CC050VA2RB2</b>	5
<b>CC070VA2RB2</b>	7
<b>CC100VA2RB2</b>	10
<b>CC150VA2RB2</b>	15
<b>CC200VA2RB2</b>	20
<b>CC300VA2RB2</b>	30

# 2 Extension Cable Sets (RoHS), Flexible Extension Cable Sets (RoHS)

- Extension Cable Sets
- ◇ For Standard Type Motor



Cable for Motor

Product Name	Length L(m)
<b>CC010VA2F2</b>	1
<b>CC020VA2F2</b>	2
<b>CC030VA2F2</b>	3
<b>CC050VA2F2</b>	5
<b>CC070VA2F2</b>	7
<b>CC100VA2F2</b>	10
<b>CC150VA2F2</b>	15
<b>CC200VA2F2</b>	20

- ◇ For Electromagnetic Brake Type Motor



Cable for Motor

Cable for Electromagnetic Brake

Product Name	Length L(m)
<b>CC010VA2FBT2</b>	1
<b>CC020VA2FBT2</b>	2
<b>CC030VA2FBT2</b>	3
<b>CC050VA2FBT2</b>	5
<b>CC070VA2FBT2</b>	7
<b>CC100VA2FBT2</b>	10
<b>CC150VA2FBT2</b>	15
<b>CC200VA2FBT2</b>	20

- Flexible Extension Cable Sets
- ◇ For Standard Type Motor



Cable for Motor

Product Name	Length L(m)
<b>CC010VA2R2</b>	1
<b>CC020VA2R2</b>	2
<b>CC030VA2R2</b>	3
<b>CC050VA2R2</b>	5
<b>CC070VA2R2</b>	7
<b>CC100VA2R2</b>	10
<b>CC150VA2R2</b>	15
<b>CC200VA2R2</b>	20

- ◇ For Electromagnetic Brake Type Motor



Cable for Motor

Cable for Electromagnetic Brake

Product Name	Length L(m)
<b>CC010VA2RBT2</b>	1
<b>CC020VA2RBT2</b>	2
<b>CC030VA2RBT2</b>	3
<b>CC050VA2RBT2</b>	5
<b>CC070VA2RBT2</b>	7
<b>CC100VA2RBT2</b>	10
<b>CC150VA2RBT2</b>	15
<b>CC200VA2RBT2</b>	20

## Dimension (Unit = mm)

### Connection Cable

#### ◇ Cable for Motor

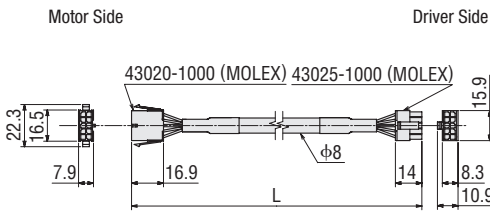

#### ◇ Cable for Electromagnetic Brake

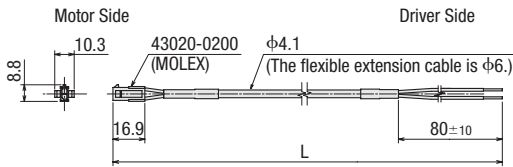

### Extension Cable

#### ◇ Extension Cable for Motor

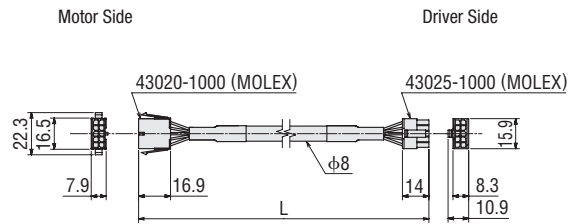

#### ◇ Cable for Electromagnetic Brake

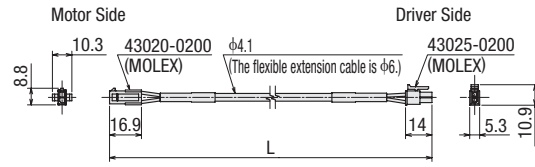

## Note on use of flexible extension cable

① Do not allow the cable to bend at the cable connector.

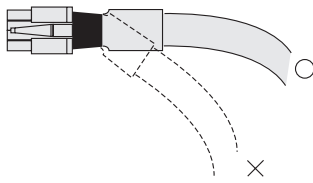

② For the bending radius, use at 6 times or more of the cable diameter.

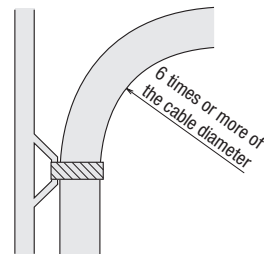

③ The cable from the motor and the accessory cable are not for bending. If the motor cable is to be bent, bend it at the flexible cable.

#### • Flexible Connection Cable

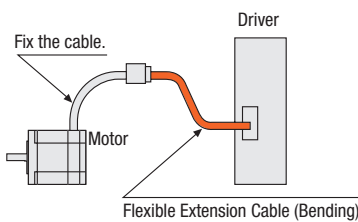

#### • Flexible Extension Cable

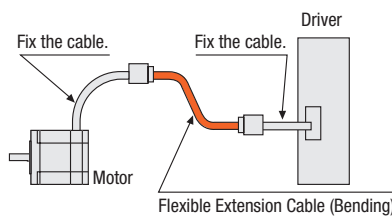

# Driver Cable

## 1 General-Purpose Cable (RoHS)



This shielded cable has a half-pitch connector at one end of the cable for easy connecting to the driver.

### Note

- Note that as the length of the pulse signal line between the driver and controller increases, the maximum transmission frequency decreases.
- Install a connector that matches the controller you are using to the other end of the cable.

### Product Line

Product Name	Applicable	Length L (m)
<b>CC36D1-1</b>	<b>ARD-K</b>	1
<b>CC36D2-1</b>	For CN5 (36 pins)	2

### Dimension (Unit = mm)

#### CC36D1-1, CC36D2-1

Conductor: AWG28 (0.08 mm<sup>2</sup>)

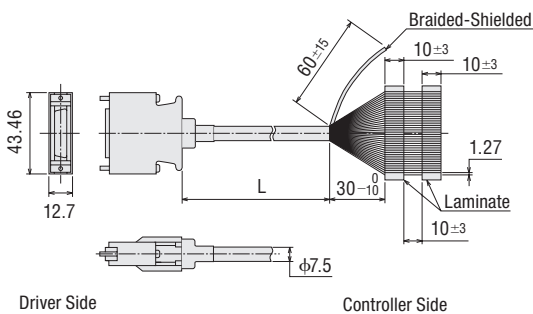

## 2 Connector - Terminal Block Conversion Unit (RoHS)



CC36T1

This is a conversion unit that connects a driver to a programmable controller using a terminal block.

- Includes a signal name plate for easy, one-glance identification of driver signal names
- DIN-rail installable
- Cable Length: 1 m

### Product Line

Product Name	Applicable	Length m
<b>CC36T1</b>	<b>ARD-K</b> For CN5 (36 pins)	1

### Dimension (Unit = mm)

#### CC36T1

CAD B438

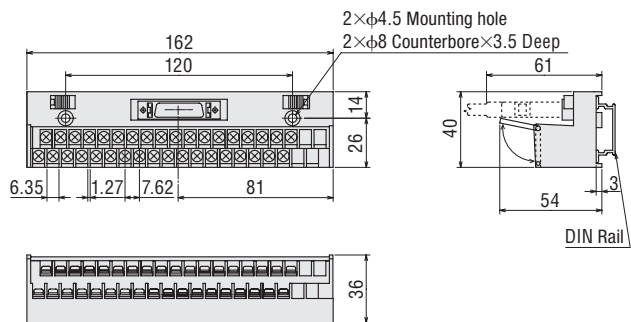

#### Terminal Block Pin No.

19	20	21	22	23	24	25	26	27	28	29	30	31	32	33	34	35	36
1	2	3	4	5	6	7	8	9	10	11	12	13	14	15	16	17	18

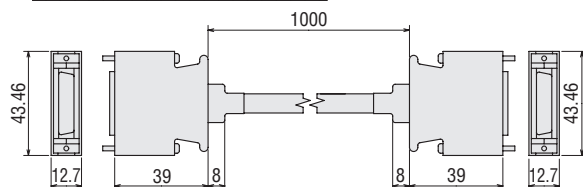

- Applicable Crimp Terminal
  - Terminal Screw Size: M3
  - Tightening Torque: 1.2 N·m
  - Minimum Applicable Lead Wire: AWG22 (0.3 mm<sup>2</sup>)

### Note

- Round terminals cannot be used.

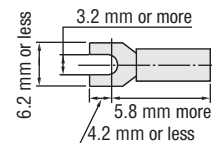

# Battery Set RoHS

You need to connect a battery set to use a built-in controller driver as an absolute backup system.

## Product Line

Product Name	Applicable
<b>BAT01B</b>	<b>ARD-KD</b>



## Specifications

Item	Content
Battery Type	Sealed nickel-metal hydride rechargeable single cells
Nominal Voltage	2.4 V
Rated Capacity	1900 mAh
Expected Life	Approx. 4 years*1
Charge Time	32 hours*1
Data Retention Period	Approx. 360 hours (approx. 15 days)*1*2
Operating Ambient Temperature	0~+40°C (non-freezing)
Operating Ambient Humidity	45~85% (non-condensing)

\*1 At an ambient temperature of 20°C  
\*2 After the power is cut OFF at full charge

## Dimensions (Unit = mm)

Mass: 0.1kg  
CAD B560

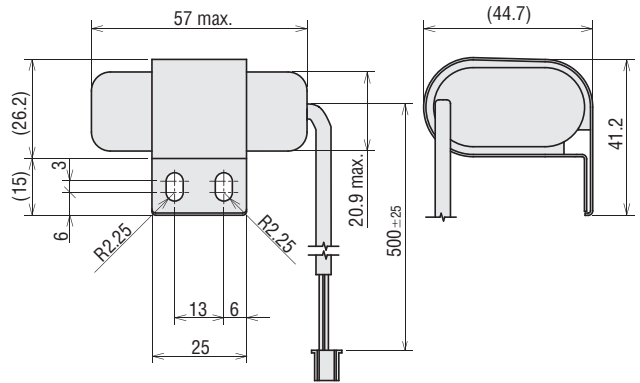

# RS-485 Cable RoHS

This cable is used to connect built-in controller drivers with each other for multi-axis operation.

## Product Line

Product Name	Applicable	Length L (m)
<b>CC001-RS4</b>	<b>ARD-KD</b>	0.1
<b>CC002-RS4</b>		0.25



## Dimensions (Unit = mm)

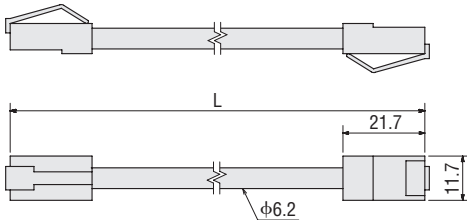

● Connection Example

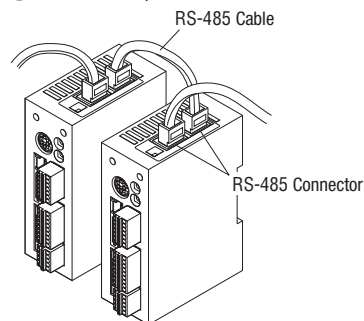

# Network Converter RoHS

The network converter converts higher layer protocol to Oriental Motor's proprietary RS-485 protocol. It enables you to control Oriental Motor's RS-485 compatible products under higher layer protocol environment.

## Product Line

Network Type	Product Name
CC-Link- Compatible	<b>NETC01-CC</b>
MECHATROLINK- II Compatible	<b>NETC01-M2</b>
MECHATROLINK- III Compatible	<b>NETC01-M3</b>



**NETC01-CC**



**NETC01-M2**



**NETC01-M3**

Features

Lineup

System Configuration

Product Line

Specifications and Characteristics

Dimension

Connection and Operation

Combination List

Extended Functions

How to Read Specifications and Characteristics

Accessory

Controller

# Flexible Coupling

A flexible coupling ideal for the **AR** Series is available. Once you have decided on a type and/or applications of motor/gear, you can select the recommended size of coupling easily. All motor shaft diameters of stepping motor packages are available (including geared motors).



MCV Coupling



MC Coupling



MCS Coupling

## Selecting a Coupling

Coupling Type	Motor Type			Application
	Standard	TH Geared PS Geared PN Geared Harmonic Geared		
MCV Coupling	⊙	—		High position accuracy and vibration suppression
MC Coupling	⊙	—		High Positioning Accuracy
MCS Coupling	○	⊙		High Strength and High Positioning Accuracy

## MCV Coupling RoHS

This one-piece coupling is made by forming a rubber isolator in an aluminum alloy hub.

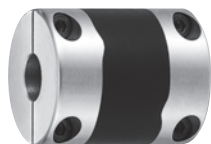

## Product Line

Product Name

MCV15

MCV19

MCV25

MCV30

● A number indicating the coupling inner diameter is entered where the box  is located within the product name.

## Product Number Code

# MCV 30 10 14

①      ②      ③      ④

①	MCV Coupling
②	Outer Diameter of Coupling
③	Inner Diameter d1 (Smaller side) ( <b>06A</b> represents $\phi 6.35$ mm.)
④	Inner Diameter d2 (Larger inner diameter)

● For inner diameter d1, the smaller of the motor shaft diameter or the driven shaft diameter is entered.  
 For inner diameter d2, the larger of the motor shaft diameter or the driven shaft diameter is entered.

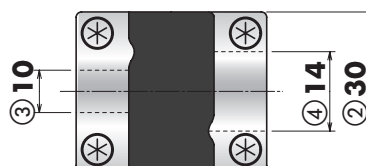

## Coupling Selection Table

Type	Series		Coupling Type	Motor Shaft Diameter mm	Driven Shaft Diameter mm										
	Frame Size	Product Name			03	04	05	06	06A	08	10	12	14	15	
					$\phi 3$	$\phi 4$	$\phi 5$	$\phi 6$	$\phi 6.35$	$\phi 8$	$\phi 10$	$\phi 12$	$\phi 14$	$\phi 15$	
Standard Type	28 mm	AR24, AR26	MCV15	05	$\phi 5$	●	●	●	●						
	42 mm	AR46	MCV19	06	$\phi 6$			●	●		●				
	60 mm	AR66, AR69	MCV25	10	$\phi 10$				●	●	●	●			
	85 mm	AR98	MCV30	14	$\phi 14$						●	●	●	●	●

# MC Coupling RoHS

This is a slit-type one-piece coupling.



Set Screw Type



Clamp Type

## Product Line

### Set Screw Type

Product Name
<b>MC12</b> □ <b>S</b>
<b>MC16</b> □ <b>S</b>
<b>MC25</b> □ <b>S</b>
<b>MC32</b> □ <b>S</b>

### Clamp Type

Product Name
<b>MC12</b> □ <b>C2</b>
<b>MC16</b> □ <b>C2</b>
<b>MC25</b> □ <b>C2</b>
<b>MC32</b> □ <b>C2</b>

● A number indicating the coupling inner diameter is entered where the box □ is located within the product name.

## Product Number Code

# MC 25 08 10 S

- ①    ②    ③    ④    ⑤

①	<b>MC</b> Coupling
②	Outer Diameter of Coupling
③	Inner Diameter d1 (Smaller side) ( <b>06A</b> represents $\phi 6.35$ mm.)
④	Inner Diameter d2 (Larger inner diameter)
⑤	Connection Method <b>S</b> : Set Screw Type <b>C2</b> : Clamp Type

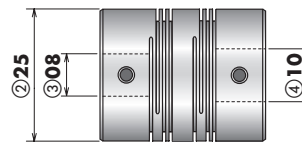

● For inner diameter d1, the smaller of the motor shaft diameter or the driven shaft diameter is entered.  
 For inner diameter d2, the larger of the motor shaft diameter or the driven shaft diameter is entered.

## Coupling Selection Table

Type	Series		Coupling Type	Motor Shaft Diameter mm	Driven Shaft Diameter mm										
	Frame Size	Product Name			04	05	06	06A	08	10	12	14	16		
					$\phi 4$	$\phi 5$	$\phi 6$	$\phi 6.35$	$\phi 8$	$\phi 10$	$\phi 12$	$\phi 14$	$\phi 16$		
Standard Type	28 mm	<b>AR24, AR26</b>	<b>MC12</b>	<b>05</b>	$\phi 5$	◎	◎	○							
	42 mm	<b>AR46</b>	<b>MC16</b>	<b>06</b>	$\phi 6$	○	◎	○		○					
	60 mm	<b>AR66</b>	<b>MC25</b>	<b>10</b>	$\phi 10$			◎	◎	◎	○				
		<b>AR69</b>	<b>MC32</b>	<b>10</b>	$\phi 10$				◎	◎	◎	◎			
	85 mm	<b>AR98</b>	<b>MC32</b>	<b>14</b>	$\phi 14$						◎	◎	◎	○	

◎ Common for both the set screw type and clamp type  
 ○ Only for the set screw type

Features

Lineup

System Configuration

Product Line

Specifications and Characteristics

Dimension

Connection and Operation

Combination List

Extended Functions

How to Read Specifications and Characteristics

Accessory

Controller



# Motor Installation Bracket (RoHS)

Installation brackets are convenient for installation and securing a stepping motor and geared type stepping motor.



## Product Line

### Standard Type

Material: Aluminum alloy

Product Name	Motor Frame Size	Applicable Product
<b>PAFOP</b>	42 mm	<b>AR46</b>
<b>PALOP</b>		
<b>PAL2P-5</b>	60 mm	<b>AR66</b> <b>AR69</b>
<b>PAL4P-5</b>	85 mm	<b>AR98</b>

- The installation bracket base is built with holes large enough to allow for adjustments of belt tension after a motor is installed.
- These installation brackets can be perfectly fitted to the pilot of the stepping motors (excluding **PALOP**).

#### Note

- Not available for geared type.

### TH Geared Type

Material: Aluminum alloy

Product Name	Motor Frame Size	Applicable Product
<b>SOLOB</b>	42 mm	<b>AR46</b>
<b>SOL2A</b>	60 mm	<b>AR66</b>
<b>SOL5B</b>	90 mm	<b>AR98</b>

- Use the screws provided to install the **SOL2A**. Since screws are not included with **SOLOB**, and **SOL5B**, prepare appropriate screws separately.

### PS Geared Type, PN Geared Type

Material: SS400

Surface Treatment: Electroless nickel plating

Product Name	Motor Frame Size	Applicable Product
<b>PLA60G</b>	60 mm	<b>AR66</b>
<b>PLA90G</b>	90 mm	<b>AR98</b>

- The installation bracket base is built with holes large enough to allow for adjustments of belt tension after a motor is installed.
- Motor installation screws are included.

### Harmonic Geared Type

Material: SS400

Surface Treatment: Electroless nickel plating

Product Name	Motor Frame Size	Applicable Product
<b>PLA60H</b>	60 mm	<b>AR66</b>
<b>PLA90H</b>	90 mm	<b>AR98</b>

- The installation bracket base is built with holes large enough to allow for adjustments of belt tension after a motor is installed.
- Motor installation screws are included.

For details on accessories, refer to Oriental Motor General Catalogue 2011/2012 or the personal Web catalogue on our website.  
<http://www.orientalmotor.com.sg/>

# Controller (Sold separately)

## Stored-Data Type Controller

# PG1200 (RoHS)

## Features

All operations including data setting can easily be performed using the 4 touch pads on the panel. In addition, the number of signal lines is reduced to a minimum for easy operation and connection.

Jerk Limiting Control Function Suppresses Motor Drive Vibration

- Sequential-Step Positioning Operation/External Signal Operation Possible
- Maximum Oscillation Frequency 200 kHz
- 1-Pulse Output/2-Pulse Output Mode Select Possible

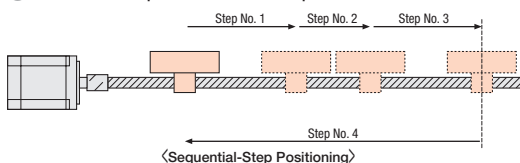

Recessed Installation Model      DIN Rail Installation Model

## Product Line

### Sink Logic

Product Line	Product Name
DIN Rail Installation Model	<b>PG1200N-D</b>
Recessed Installation Model	<b>PG1200N-U</b>

### Source Logic

Product Line	Product Name
DIN Rail Installation Model	<b>PG1200P-D</b>
Recessed Installation Model	<b>PG1200P-U</b>

Features

Lineup

System Configuration

Product Line

Specifications and Characteristics

Dimension

Connection and Operation

Combination List

Extended Functions

How to Read Specifications and Characteristics

Accessory

Controller



### Safety Precautions

- To ensure correct operation, carefully read the Operating Manual before using it.
- The products listed in this catalogue are for industrial use and for built-in component. Do not use for any other applications.

- The factories which manufacture the products listed in this catalogue have obtained Quality Management Systems ISO9001 and Environment Management Systems ISO14001.
- The content listed in this catalogue such as performance and specifications of the products are subject to change without notice for improvements.
- The price of all products listed in this catalogue does not include the consumption tax etc.
- For details of the products, please contact the nearest dealer, sales office or the following "Order Support Center" or "Customer Support Center".
- CClink is a registered trademark of CC-Link Partner Association.
- MECHATROLINK-II is a registered trademark of YASUKAWA ELECTRIC CORPORATION.
- Modbus is a registered trademark of Schneider Automation Inc..
- **Orientalmotor** **αSTEP** and **FLEX** are registered trademark or trademark of Oriental Motor in Japan and other countries.

# Orientalmotor

## SINGAPORE ORIENTAL MOTOR PTE LTD

31 Kaki Bukit Road 3, #04-02/04  
 Techlink, Singapore 417818  
 TEL: +65-6745-7344 FAX: +65-6745-9405  
<http://www.orientalmotor.com.sg/>

## ORIENTAL MOTOR (THAILAND) CO., LTD.

900, 8th Floor Zone C, Tonson Tower, Ploenchit Road,  
 Lumpini, Pathumwan, Bangkok 10330 Thailand  
 TEL: +66-2-251-1871 FAX: +66-2-251-1872  
<http://www.orientalmotor.co.th/>

## ORIENTAL MOTOR (INDIA) PVT.LTD.

No.810, 8th Floor, Prestige Meridian-1 No.29,  
 M.G.Road, Bangalore, 560001, India  
 TEL: +91-80-41125586 FAX: +91-80-41125588  
<http://www.orientalmotor.co.in/>

## Customer Support Centre

TEL: For Singapore: 1800-8420280 (Toll Free)  
 For Malaysia: 1800-806161 (Toll Free)  
 For Thailand: 1800-888881 (Toll Free)  
 For Other Countries: +65-6842-0280  
 Mail to: [support@orientalmotor.com.sg](mailto:support@orientalmotor.com.sg)

## ORIENTAL MOTOR (MALAYSIA) SDN. BHD.

**Headquarters & Kuala Lumpur Office**  
 A-13-1, North Point Offices, Mid Valley City,  
 No.1 Medan Syed Putra Utara 59200  
 Kuala Lumpur, Malaysia  
 TEL: +60-3-22875778 FAX: +60-3-22875528

### **Penang Office**

TEL: +60-4-6423788 FAX: +60-4-6425788

### **Johor Bahru Office**

TEL: +60-7-3314257 FAX: +60-7-3314259  
<http://www.orientalmotor.com.my/>

## Japanese Customer Support Centre

TEL: +65-6745-3008  
 Mail to: [j-support@orientalmotor.com.sg](mailto:j-support@orientalmotor.com.sg)

For more information please contact:



36 Taunton Drive Cheltenham VIC 3192  
[info@idyna.com.au](mailto:info@idyna.com.au) 03 9585 2739  
[www.industrialdynamics.com.au](http://www.industrialdynamics.com.au)

- |                  |                      |                                 |
|------------------|----------------------|---------------------------------|
| • Linear Guides  | • Lead/Ballscrews    | • Precision Planetary Gearboxes |
| • Stepper motion | • Robotic Modules    | • Linear/Direct Drives          |
| • Rack & Pinion  | • Electric Cylinders | • Geared AC Motors              |
| • Rotary Tables  | • Linear Actuators   | • Support Bearings              |
|                  |                      | • Screw Jacks                   |
|                  |                      | • Pneumatics                    |
|                  |                      | • Lubrication                   |